



**CONFERENCE  
PROCEEDINGS**



**FPT UNIVERSITY STUDENT RESEARCH CONFERENCE**

# **PROCEEDINGS**

**FPT UNIVERSITY**

**Volume 5  
SEPTEMBER 2018**

**FPT UNIVERSITY**

**FPT UNIVERSITY STUDENT RESEARCH CONFERENCE**  
**PROCEEDINGS**

**Summer Semester 2018**  
**Volume 5**

**September, 2018**  
**Ho Chi Minh, Viet Nam**





**Table of Content**

<b>Introduction.....</b>	<b>i</b>
<b>Organizers, Faculty Advisors, Program Committee.....</b>	<b>ii</b>
<b>Conference Program.....</b>	<b>iii</b>
<b>Keynote Speech: Perceived Tourism Service Quality of Chinese Outbound Tourists: A Case Study of Nha Trang Tourism Industry</b>	
Doan Kim Loan .....	1
<b>Papers of Economic Sector.....</b>	<b>9</b>
<b>Analyze the Current Situation of Sabeco’s Marketing Communication Programs and Giving Recommendations for Improving Its IMC Strategy</b>	
Huynh Tieu My, Luong Nhat Duy, Nguyen Duc Duy, Tran Xuan Dac.....	11
<b>Analyzing the Difference in Service Quality Between Local and International Banks in Vietnam</b>	
Doan Thi Thanh Giang, Duong Huynh Thao Nguyen, Hoang Phuong Anh, Vo Van Thanh Nhat, Le Thu Huyen.....	17
<b>Analyzing the Relationship of Ethnocentrism, Animosity and Nostalgia on Vietnamese Household Purchasing Decision: A Case Study of Chinese Imported Goods</b>	
Huynh Gia Thuy, Pham Tien Tung, Tran Hong Ngoc Thuy, Nguyen Huu Minh Tam, Nguyen Quang Hai .....	23
<b>Papers of Technical Sector .....</b>	<b>31</b>
<b>Call-Center on Mobile for Clinics</b>	
Nguyen The Phuong, Phan Thanh Thuan, Nguyen Cao Duy, Nguyen Luong Tuan Kiet .....	33
<b>Criminal Face Detection</b>	
Le Hung Son, Vo Hoang Viet, Nguyen Thanh Nha, Nguyen Kien Huy.....	37
<b>Vietnamese Keyword Extraction Using Deep Learning Approach</b>	
Nguyen Toan Nguyen, Hoang Manh Cuong, Ha Huy Hoang, Dam Tien Nam.....	41
<b>Design and Implement Street Lighting Control System Using Power Line Communication</b>	
Vo Truong Thinh, Truong Chieu Khang, Tran Tat Dat .....	48
<b>Electricity Invoice System</b>	
Duong Trieu Anh, Hoang Nguyen Minh Giang, Ngo Quang Duy, Dang Manh Hung.....	53
<b>Design and Construction Sun Drying Wet Clothes System</b>	
Hoang Phi Long, Nguyen Dinh Phong, Trinh Binh.....	56
<b>Get a Tour Guide near Tourists</b>	
Nguyen Bui Hoang Minh, Doan Bao Quyen, Le Thien Duy .....	61
<b>Human Resource Sharing for Software Company</b>	
Nguyen Nhat Ha, Ho Thai Thien, Vo Cong Phuc, Pham Tran Anh Tu.....	65
<b>Conference Participants .....</b>	<b>69</b>
<b>Awards &amp; Photos Appendix .....</b>	<b>73</b>



### About the Proceedings

*The Student Reseach Conference Proceedings is periodical publication follow every semester of FPT University.*

The Proceedings gather all the papers of the lecturers, researchers in the conference, and the main content is the student's subject papers had defended in front of the scientific council, with a scientific content highly actual, acceptable post in the Proceedings.

At present, The Student Reseach Conference Proceedings was published by English language. This is being published for internal circulation only.

Readers can find it in the Library Department of HCMC FPT University and Ha Noi FPT University, also find it with electronic version on Dspace at: <http://ds.libol.fpt.edu.vn>

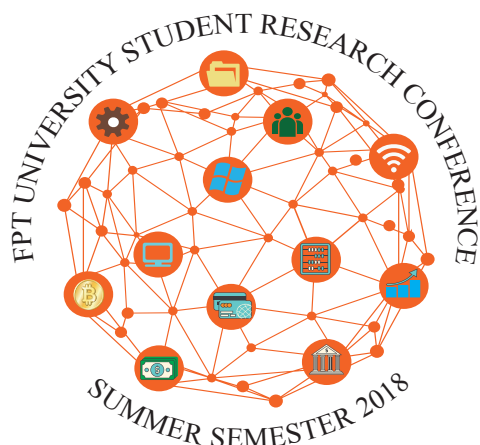

### Introduction

In the context of exchange and international integration of Vietnam today, universities in general and FPT University in HCM City in particular are attaching importance to the development of scientific research. This is seen as a complementary way of training, improving the teaching and learning process in universities and the results of scientific research that promise to deliver groundbreaking practical applications.

During last year, the scientific research activities of FPT University students have always been considered as the focus and received special attention from the Executive Board, Heads of Departments and many students. Through the process of scientific research, with the help of specialized mentors, students will have the opportunity to develop academic skills, searching capabilities and document collecting into a theoretical basis for their research. In addition, students also learn logical inference, data analysis, algorithm, and so on. This is a fun, exciting but challenging playground that requires serious and creative work from both students and mentors.

Following the success of the student research program in 2017, in September 2018, the “FPT University Student Research Conference” was held for the fifth time. This is the chance which not only creates best conditions for students can report the results of their research to the Scientific Council; also contributes to encourage and promote research activities in students. Besides that, this is seen as an opportunity for students to exchange their knowledge and to build a “*research culture*” in the university environment.

The fifth conference has attracted a large number of students involved in variety and high applied topics. With a total of 27 topics in three areas: Software Engineering, Information Assurance and Business Administration, the Scientific Council was selected 7 topics to present in this conference.

In the next term, the organizers would like to have more students to participate in scientific research, applying the theory learned into research and practice in order to accumulate knowledge on the way to start a business later.

We are sincerely thankful to mentors who are dedicated to guide students so that they can know and understand how scientific research; also find the passion in this activity.

Best regards.

## **Organizers**

Tran Ngoc Tuan, Ph.D. (Vice Rector of FPT University)

Than Van Su, M.E (Head of Academic Affairs Department, HCMC FPT University)

Kieu Trong Khanh, M.E (Head of ITS Department, HCMC FPT University)

Vo Minh Hieu, MBA. (Head of Business Faculty, HCMC FPT University)

Ngo Dang Ha An, M.E (Head of IA Department, HCMC FPT University)

Dinh Truong Lam (Head of Library Department, HCMC FPT University)

Pham Trong Phuong Tra (Library Officer of Library Department, HCMC FPT University)

Bui Thi Kieu (Library Officer of Library Department, HCMC FPT University)

Nguyen Duy Phuong (Library Officer of Library Department, HCMC FPT University)

## **Faculty Advisors**

Kieu Trong Khanh M.E (Head of IS Department, HCMC FPT University)

Nguyen Huy Hung, M.E (Head of SE Department, HCMC FPT University)

Ton That Nhu Nhat, MBA. (Lecturer of MKT Department, HCMC FPT University)

Vu Le Van, MBA. (Lecturer of MKT Department, HCMC FPT University)

Tran Dinh Thanh, MBA. (Lecturer of MKT Department, HCMC FPT University)

Vo Minh Hieu, MBA. (Lecturer of MKT Department, HCMC FPT University)

Ngo Dang Ha An, M.E (Head of IA Department, HCMC FPT University)

Nguyen Duc Loi, M.E (Lecturer of ES Department, HCMC FPT University)

Bui Thanh Hung, M.E (Lecturer of IS Department, HCMC FPT University)

## **Program Committee**

Than Van Su, M.E (Head of Academic Affairs Department, HCMC FPT University)

Nguyen Trong Tai, M.E (Lecturer of Technical Sector, HCMC FPT University)

Nguyen Huy Hung, M.E (Lecturer of Technical Sector, HCMC FPT University)

Nguyen Quoc Cuong, MBA. (Lecturer of Economic Sector, HCMC FPT University)

Ho Yen Thuc, MBA. (Lecturer of Economic Sector, HCMC FPT University)

Nguyen Huu Hoang Giao, MBA. (Lecturer of Economic Sector, HCMC FPT University)

## **Editor**

Nguyen Huy Hung, M.E (Head of SE Department, HCMC FPT University)

## Conference Program

Saturday, September 1<sup>st</sup>, 2018

- 07:30 - 08:00** Welcome Delegates and Guests
- 08:00 - 08:10** Introduction of conference opening - Speech of Tran Ngoc Tuan, Ph.D., Vice Rector of FPT University
- 08:10 - 08:30** **Keynote Speech 1: Reduce Risk to Ransomware Attack and Improve Operational Security**  
Presented by Nguyen Sieu Dang, M.I.T
- 08:30 - 08:50** **Keynote Speech 2: Perceived Tourism Service Quality of Chinese Outbound Tourists: A Case Study of Nha Trang Tourism Industry**  
Presented by: Doan Kim Loan

### Reports of Students from Economic Sector

- 08:50 - 09:10** **Analyzing the Factors of Choosing Payment Methods in Online Shopping: A Study of Atadi.vn**  
Presented by: Diep Phuong Thanh, Dinh Trung Hieu, Lai Thi Thao My, Pham Huynh Vinh Phuong
- 09:10 - 09:30** **Evaluating the Disability Customers' Satisfaction of the Public Transportation in Ho Chi Minh City**  
Presented by: Phan Duc Minh, Hoang Thi Tu Anh, Trinh Thi Yen Anh

### 09:30 - 09:40 Tea-break

### Reports of Students from Technical Sector

- 09:40 - 10:00** **Call-Center on Mobile for Clinics**  
Presented by: Nguyen The Phuong, Phan Thanh Thuan, Nguyen Cao Duy, Nguyen Luong Tuan Kiet
- 10:00 - 10:20** **Criminal Face Detection**  
Presented by: Le Hung Son, Vo Hoang Viet, Nguyen Thanh Nha, Nguyen Kien Huy
- 10:20 - 10:40** **Vietnamese Keyword Extraction Using Deep Learning Approach**  
Presented by: Nguyen Toan Nguyen, Hoang Manh Cuong, Ha Huy Hoang, Dam Tien Nam
- 10:40 - 11:00** **Design and Implement Street Lighting Control System Using Power Line Communication**  
Presented by: Vo Truong Thinh, Truong Chieu Khang, Tran Tat Dat
- 11:00 - 11:20** **Electricity Invoice System**  
Presented by: Duong Trieu Anh, Hoang Nguyen Minh Giang, Ngo Quang Duy, Dang Manh Hung

### 11:20 - 11:45 Awards Ceremony

### 11:45 - 13:00 Lunch Time



# Keynote Speech: Perceived Tourism Service Quality of Chinese Outbound Tourists: A Case Study of Nha Trang Tourism Industry

**Doan Kim Loan**

FPT University HCMC, Viet Nam

**Abstract**

*With the development of personal income, tourism trends become indispensable, especially for Chinese people. They not only enjoy the vacation in their country but also travel overseas. When they go abroad to travel, perceived tourism service quality is a crucial concept with directly affect the success or failure of tourism industry. This report would like to find out what factors affect to their perceived quality in case of Nha Trang tourism industrial. The author also figures out how they affect this perceived quality. Finally, this research will give some recommendations for Nha Trang tourism service in specific and for Vietnam tourism service in general to help them attract more Chinese tourists.*

**Keywords**

*Perceived Tourism Service Quality, Outbound Tourists, Destination*

**I. INTRODUCTION**

**1.1. Research Background**

According to statistics from the China National

Tourism Administration (CNTA), Chinese tourists traveled overseas on 131 million occasions in 2017, an increase of 7.0% from the previous year with 122 million outbound tourists. China has remained the world’s largest number of outbound tourists for consecutive years. Besides, because of the easing visa requirements, some of the countries become dark horse destinations receiving increasing Chinese tourists, and Vietnam is in the top.

**1.2. Research Objectives**

There are 5 main objectives which include:

- Understand the Perceived tourism service quality of Chinese outbound tourists
- Find out factors affecting the Perceived tourism service quality of Chinese outbound tourists
- Find out the relationships between the factors affecting Perceived quality
- Identify the difference in Perceived quality between sex, aging, job, and income
- Suggest the implication to improve the Perceived tourism service quality of Chinese outbound tourists.

**II. LITERATURE REVIEW**

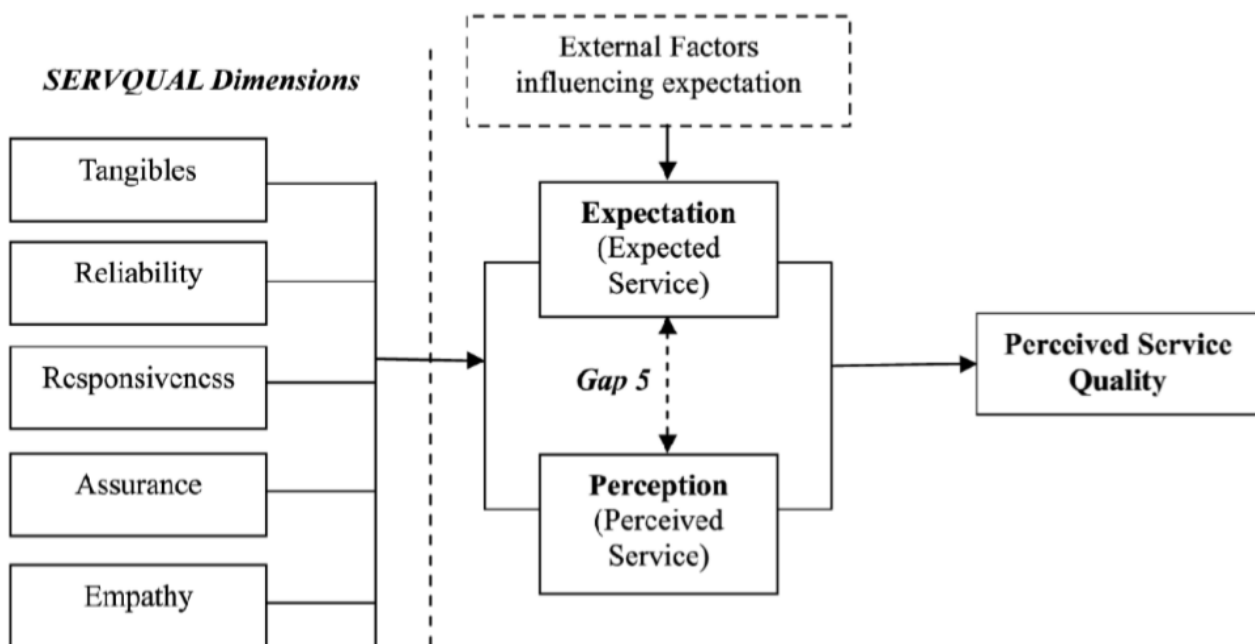

**Figure 1: SERVQUAL Model**



For this study, the author uses service quality model - SERVQUAL and applied in the context of destination.

In order to measure the expectations and perceptions of service quality of consumer, the researcher used SERVQUAL model. Originally, Parasuraman et al. (1985) identified five organizational gaps within the process of service design/delivery that cause deficits in quality and leading to dissatisfied customers. However, after they refined the research, they change from the original ten dimensions of service quality (proposed in their work in 1985) to five (Parasuraman et al., 1988). According to Parasuraman et al. (1988), having five factors which affect to service quality: Tangibles (the environment of an agency and how their staff appears), Reliability (the ability of serving tourists in a dependable way), Responsiveness (a willingly and promptly serve the tourists), Assurance (the way an agency making the tourists feel safe and easy around the destination) and Empathy (the ability to understand the needs of the tourists).

According to Parasuraman et al. (1988), we have five following definitions:

**Tangibles (TG)**

Tangible is a “Physical facilities, equipment and appearance of personnel”. In another word, it is an ambiance of the destination and how the working staff appears to be.

**Reliability (RL)**

Reliability is an “Ability to perform the promised service dependably and accurately”. In another word, it is an ability to serve customers adequately and in time.

**Responsiveness (RP)**

Responsiveness is a “Willingness to help customers and provide prompt service”. In another word, it is the destination’s tendency to serve customers fast and with verve.

**Assurance (AS)**

Assurance is “Knowledge and courtesy of employees and their ability to inspire trust and confidence”. In another word, it is making the customers feel safe and easy around the destination environment

**Empathy (EP)**

Empathy is “Caring individualized attention the firm provides to its customers”. In another word, it is ability to understand the needs of the customer, to get in the “shoes” of the customer.

**III. THEORETICAL FRAMEWORK AND HYPOTHESIS DEVELOPMENT**

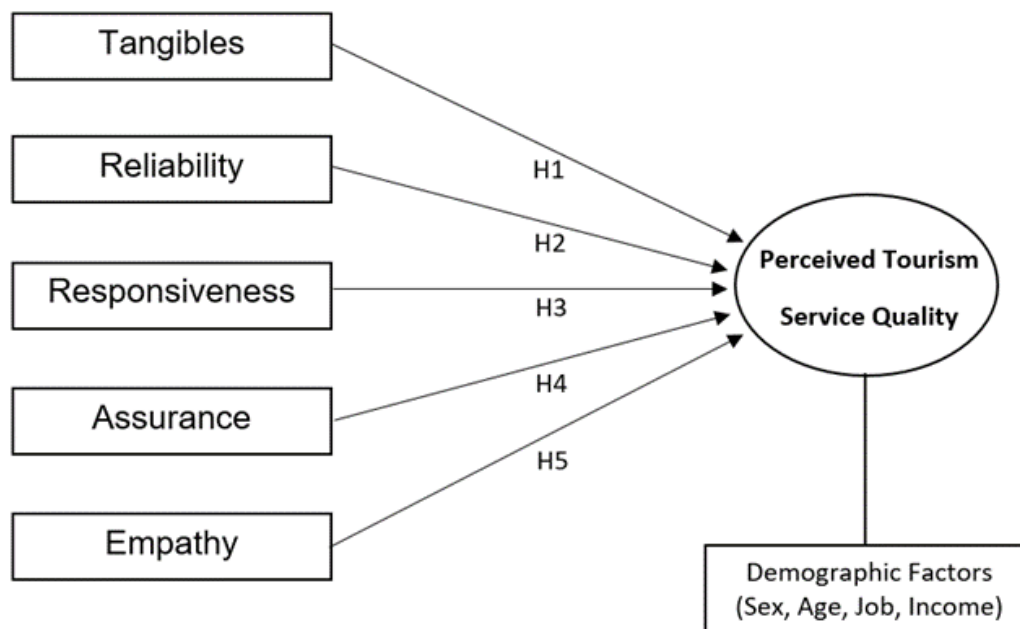

**Figure 2: The overall model**

**H1:** There is a significant relationship between Tangibles and Perceived tourism service quality

**H2:** There is a significant relationship between Reliability and Perceived tourism service quality

**H3:** There is a significant relationship between Responsiveness and Perceived tourism service quality

**H4:** There is a significant relationship between Assurance and Perceived tourism service quality

**H5:** There is a significant relationship between Empathy and Perceived tourism service quality

## IV. METHODOLOGY AND DATA OVERVIEW

### 4.1. Methodology

This research uses quantitative approach with the data is collected from questionnaire which includes three parts: screening questions, main questions and demographic information. Chinese language is used for this questionnaire because all of the respondents are Chinese people.

### 4.2. Data overview

The primary data is collected from 350 Chinese tourists who were traveling in Nha Trang, Vietnam at the age of 18 to 60. After doing this research, no response is invalid.

## V. RESULT AND FINDING

### 5.1. Reliability test

Table 1 presents the Cronbach's Alpha for five independent variables and a dependent variable. According to Hoang T and Chu N.M.N (2005), the reliability of the scale is estimated by using the Cronbach's Alpha coefficient and the acceptable one are ranged from 0.6 to smaller than 1.

The result in the following table shows that the value range of is from 0.708 to 0.749. As a result, these variables are reliable.

ID	Variable name	Number of items	Cronbach's Alpha
TG	Tangibles	3	0.736
RL	Reliability	3	0.749
RP	Responsiveness	3	0.708
AS	Assurance	3	0.723
EP	Empathy	3	0.724
PT	Perceived Tourism Service Quality	3	0.743

**Table 1: Preliminary evaluation of Cronbach's Alpha reliability scale**

### 5.2. Exploratory Factor Analysis (EFA)

KMO and Bartlett's Test		
Kaiser-Meyer-Olkin Measure of Sampling Adequacy		.621
Bartlett's Test of Sphericity	Approx. Chi-Square	1707.678
	df	105
	Sig.	.000

**Table 2: Summary Result of EFA**

To analyze the Rotated Component Matrix, the researcher has to ensure criteria such as KMO and Bartlett Sig.

Kaiser Meyer Olkin (KMO) measures the sampling adequacy (which determines if the responses given with the sample are adequate or not) which should

be close than 0.5 for a satisfactory factor analysis to proceed. Kaiser (1974) recommend 0.5 (value for KMO) as minimum (barely accepted), values between 0.7 and 0.8 are acceptable, and values above 0.9 are superb. With the result from table 2, KMO is 0.621 which is higher than 0.5, so factor analysis is appropriate. Besides, Bartlett with sig. equal 0.000 is lower than 0.05, so observed variables are correlated in overall.

Exploratory Factor Analysis (EFA) is a technique to reduce a set of observational variables to a smaller number of factors but these still demonstrate most of the information content and statistical significance of the initial set of variables (Hair et al, 1998). Each observation variable will be weighted as a factor called Factor Loading, which tells the researchers which factor each variable will belong to.

The selected observational variable is the factor whose Factor Loading is greater than or equal to 0.5. Table 3 illustrates the Rotated Component Matrix, every factors are higher than 0.5, so these factors can ensure about meaning and do not eliminate any one.

	Component				
	1	2	3	4	5
<b>RL1</b>	.828				
<b>RL3</b>	.805				
<b>RL2</b>	.750				
<b>TG3</b>		.838			
<b>TG1</b>		.823			
<b>TG2</b>		.750			
<b>RP2</b>			.860		
<b>RP1</b>			.752		
<b>RP3</b>			.738		
<b>AS2</b>				.882	
<b>AS1</b>				.727	
<b>AS3</b>				.675	
<b>EP2</b>					.824
<b>EP1</b>					.805
<b>EP3</b>					.776

**Table 3: Rotated Component Matrix**

### 5.3. Multiple Linear Regression Analysis

Model	R	R Square	Adjusted R Square	Std. Error of the Estimate
1	.738a	.545	.539	.28301

Change Statistics				
R Square Change	F Change	df1	df2	Sig. F Change
.545	82.468	5	344	.000

**Table 4: Model Summary<sup>b</sup>**

A simple linear regression analysis was conducted separately for each of the five hypotheses to test the relationships between the dependent and independent variables. Simple linear regression is the simplest form of regression analysis considering only one independent variable. As a result, the expected relationship is depicted as a straight-line relationship that can be either positive, negative or neutral. The beta value (b) represents the slope of

the regression line (Anderson, Sweeney, Williams, Camm & Cochran, 2013).

From table 4, Adjusted R Square is 0.539. It means that 53.9% dependent variable's variation (RI) can be represented by five independent variables (TG, RL, RP, AS, EP). In addition, value of Sig. F Change is lower than 0.05, so the regression analysis model is accepted.

Coefficients								
Model		Coefficients		Standardized Coefficients	t	Sig.	Collinearity Statistics	
		B	Std. Error	Beta			Tolerance	VIF
1	(Constant)	-.091	.205		-.444	.657		
	TG	.158	.022	.265	7.263	.000	.994	1.006
	RL	.332	.035	.400	9.508	.000	.745	1.342
	RP	.255	.030	.312	8.463	.000	.976	1.025
	AS	.197	.035	.239	5.714	.000	.756	1.323
	EP	.056	.022	.091	2.491	.013	.988	1.012

a. Dependent Variable: A

**Table 5: The Meaning of Particle Regression Coefficients**

In order to identify the independent variable influent on the dependent variable or not, the value of Sig. must be smaller than 0.05. For all five independent variables here, sig. values are smaller 0.05. Therefore, this result shows that independent variables have the influence on the dependent variable.

Besides, the author has to consider VIF. If the Variance inflation factor (VIF) is higher than 10, the collinearity may occur. In this research, all of 5 factors' VIF is lower than 10 (range from 1.006 to 1.342), so that situation will be rejected. After these condition are fulfill, the researcher uses a Standardized Coefficients Beta to write the regression equation and then identify which variable influences the most to invest in the most compared to other variables.

$$PT = 0.265*TG + 0.4*RL + 0.312*RP + 0.239*AS + 0.091*EP$$

Among the value of beta, the value beta of Reliability (0.4) is the most. Therefore, this factor has the greatest impact on attitude when Chinese outbound tourists perceived tourism service quality. Next factors are Responsiveness, Tangibles, Assurance and Empathy.

**5.4. Independent Samples T-Test**

	GD	N	Mean	Std. Deviation	Std. Error Mean
PT	1	203	3.6782	.39716	.02787
	2	147	3.8141	.43115	.03556

**Table 6: Group Statistics**

	Levene's Test for Equality of Variances		t-test for Equality of Means				
	F	Sig.	t	df	Sig. (2-tailed)	Mean Difference	Std. Error Difference
Equal variances assumed	.002	.967	-3.047	348	.002	-.13590	.04459
Equal variances not assumed			-3.008	298.961	.003	-.13590	.04518

**Table 7: Testing the differences in attitude by Gender**

**Ho:** There is no difference in mean perceived quality between male and female.

According to Hoang and Chu (2005), if the value of Significant in Levene’s test is less than 0.05, the null hypothesis is rejected. Then, we use the result of Equal variance not assumed. On the contrary, if significance in the Levene’s test is higher than 0.05, we accept with the hypothesis whether the variance of two independent groups is equal.

In table 7, Sig. value of Levene’s test equals 0.002, which is lower than 0.05, so Equal variances not assumed is valid. With the value of Sig. (2-tailed) is 0.03, the null hypothesis is rejected. Therefore, it means that it has the statistically significant difference in mean about perceived quality between male and female.

According to the result from table 6, mean of male’s perceived quality is higher than women 0.1359.

**5.5. ANOVA**

**5.5.1. Age**

Test of Homogeneity of Variances			
Levene Statistic	df1	df2	Sig.
.845	3	346	.470

**Table 8: Testing the differences in attitude by Age**

Because Sig = 0.47 > 0.05, it shows that the homogeneous covariance condition is satisfied that there is no difference in covariance between the groups, so ANOVA method is appropriate, and then look at ANOVA table below.

	Sum of Squares	df	Mean Square	F	Sig.
Between Groups	1.322	3	.441	2.572	.054
Within Groups	59.255	346	.171		
Total	60.577	349			

**Table 9: Testing the differences in attitude by Age (continue)**

In ANOVA table, we can see that Sig = 0.054 > 0.05, so we can claim that it has no difference mean about the attitude of tourists for each aging group.

**5.5.2. Job**

Test of Homogeneity of Variances			
Levene Statistic	df1	df2	Sig.
31.885	2	347	.000

**Table 10: Testing the differences in attitude by Job**

Because Sig = 0.000 < 0.05, it shows that the homogeneous covariance condition is not satisfied that there is not equal in covariance between the groups, so we can claim that it has no difference mean about the attitude of tourists for each aging group.

**5.5.3. Income**

Test of Homogeneity of Variances			
Levene Statistic	df1	df2	Sig.
.021	2	347	.979

**Table 12: Testing the differences in attitude by Income**

In this table, it shows that Sig = 0.979 > 0.05, it shows that the homogeneous covariance condition is satisfied that there is no difference in covariance between the groups, so ANOVA method is appropriate, so then we will look at ANOVA table.

	Sum of Squares	df	Mean Square	F	Sig.
Between Groups	.903	2	.452	2.627	.074
Within Groups	59.673	347	.172		
Total	60.577	349			

**Table 13: Testing the differences in attitude by Income (continue)**

In ANOVA table, we can see that Sig = 0.074 > 0.05, so we can claim that it has no difference mean about the Perceived tourism service quality for each income group.

*In summary, it only has the difference about the Perceived Tourism Service Quality of Chinese Outbound Tourists among gender group, not among age, job and income group.*

**VI. FINDINGS**

After researching and analyzing data, we have clarified the research objectives. This research evaluates important of critical factors to perceived quality towards tourism service of Chinese outbound tourists.

**Finding 1:** Following this research, there are five main factors which influent to tourist’s perceived quality, it includes: Tangibles, Reliability, Responsiveness, Assurance and Empathy.

**Finding 2:** Among the value of beta, the value beta of Reliability (0.4) is the most. Therefore, this factor has the greatest impact on attitude when Chinese outbound tourists perceived tourism service quality. Next factors are Responsiveness, Tangibles, Assurance and Empathy.

## VII. RECOMMENDATION AND CONCLUSION

In conclusion, the research objectives have been achieved. The author already found out five key factors affect to Perceived tourism service quality of Chinese outbound tourists. Furthermore, we also know a new thing that men are more likely to perceived quality than women. Therefore, encouraging men to use tourism service is easier than women.

In addition, in order to increase Perceived tourism service quality, tourist agencies need to improve their tangibles, reliability, responsiveness, assurance and empathy. However, the most important factor need to be developed is reliability.

## REFERENCES

- [1] Brady, M. K. & Cronin, J. J. (2001), "Some new thoughts on conceptualizing perceived service quality: A hierarchical approach", *Journal of Marketing*, Vol. 65, No. 3, pp. 34-49.
- [2] China National Tourism Administration (2017), "Chinese Outbound Tourism Statistics in 2016: 122 Million Chinese Tourists Make Outbound Trips, Spend \$109.8 Billion". Available from: <http://news.travel168.net/20170203/43145.html> [Accessed 18 Jul 2018]
- [3] Dabholkar, P. A., Thorpe, D. I. & Rentz, J. O. (1996), "A measure of service quality for retail stores: Scale development and validation", *Journal of the Academy of Marketing Science*, Vol. 24, No. 1, pp. 3-16.
- [4] Das, A., Kumar, V. & Saha, G. C. (2010), "Retail service quality in context of CIS countries", *International Journal of Quality & Reliability Management*, Vol. 27, No. 6, pp. 658-683.
- [5] Parasuraman, A., Zeithaml, V. A. & Berry, L. L. (1985), "A conceptual model of service quality and its implications for future research of service", *Journal of Marketing*, Vol. 49, No. 4, pp. 41-50.
- [6] Parasuraman, A., Zeithaml, V. A. & Berry, L. L. (1988), SERVQUAL: "A multiple item scale for measuring consumer perceptions of service quality", *Journal of Retailing*, Vol. 64, No. 1, pp. 12-40.



## APPENDIX

Code	Statements in Chinese	Statements in English	Source
<b>TG</b>		<b>Tangibles</b>	
TG1	目的地具有现代化的设备	The destination has modern looking equipment	Brady & Cronin, 2001
TG2	目的地具有干净便利的设施设备	The destination has clean and convenient physical facilities	
TG3	目的地的设施设备具有视觉吸引力	The physical facilities of the destination are visually appealing	Parasuraman, Zeithaml & Berry, 1988
<b>RL</b>		<b>Reliability</b>	
RL1	在目的地，客户所需要的各类商品应有尽有	The destination has merchandise available when the customers want it	Dabholkar, Thorpe & Rentz, 1996
RL2	目的地及时提供所预定的服务	The destination provides its services at the time it promises to do so	Das, Kumar & Saha, 2010
RL3	客户可以相信职员的行为来满足他们的需求	Customers can count on the employees taking actions to address their needs	Brady & Cronin, 2001
<b>RP</b>		<b>Responsiveness</b>	
RP1	目的地的职员能够直接并立即处理客户的投诉	Employees of the destination are able to handle customer complaints directly and immediately	Dabholkar, Thorpe & Rentz, 1996
RP2	如果职员太忙而无法及时响应客户的要求，那也没关系	It is okay if the employees are too busy to respond to customer requests promptly	Parasuraman, Zeithaml & Berry, 1988
RP3	目的地的职员快速响应客户的要求	Employees of destination respond quickly to customer needs	Brady & Cronin, 2001
<b>AS</b>		<b>Assurance</b>	
AS1	客户可以相信目的地的职员	Customers are able to trust employees of the destination	Dabholkar, Thorpe & Rentz, 1996
AS2	客户在与目的地的交易中感到安全	Customers feel safe in their transactions with the destination	Parasuraman, Zeithaml & Berry, 1988
AS3	目的地的职员总是对客户非常有礼貌	Employees in the destination are consistently polite with customers	Brady & Cronin, 2001
<b>EP</b>		<b>Empathy</b>	
EP1	职员的行为表明他们了解客户的要求	The behavior of the employees indicates that they understand customer needs	Parasuraman, Zeithaml & Berry, 1988
EP2	期望职员了解客户的要求是实际的	It is realistic to expect employees to know what the needs of their customers are	
EP3	目的地的职员给客户带来个人关注的感觉	Employees of the destination give customers personal attention	Dabholkar, Thorpe & Rentz, 1996
<b>PT</b>		<b>Perceived Tourism Service Quality</b>	
PT1	我认为旅游服务质量很好	I think tourism service quality is good	Developed by authors
PT2	我认为旅游服务质量是多种多样的	I think tourism service quality is diverse	
PT3	我认为旅游服务可以很好地满足我的要求	I think tourism service can meet my needs well	



# **Papers of Economic Sector**





# Analyze the Current Situation of Sabeco's Marketing Communication Programs and Giving Recommendations for Improving Its IMC Strategy

**Huynh Tieu My**  
FPT University  
HCMC, Viet Nam

**Luong Nhat Duy**  
FPT University  
HCMC, Viet Nam

**Nguyen Duc Duy**  
FPT University  
HCMC, Viet Nam

**Tran Xuan Dac**  
FPT University  
HCMC, Viet Nam

## Abstract

*Integrated Marketing Communication (IMC) is one element that made business going forward which aimed to approach marketing communication tools such as advertising, public relations, direct marketing, sale promotion and personal selling direct to target customers and ensure that those customers will be aware of its products or services. The best IMC will be present to strengthen relationships, which affected customer's brand awareness. To achieve this research purpose, I have studied how each IMC tools are reaching to make the awareness between product's brand and customers. The research studied consists by a literature review of study area then used methodology by questionnaire to collect data resulted according to research questions and assumptions following by analysis of collected data and presenting of what finding out.*

*The beverage industry is a significant, rapidly growing sector in Vietnam and plays a vital role in its country's economic development. SABECO is one of the leading brands in the beverage industry in Vietnam. In particular, SABECO focuses strongly on developing beer products and Saigon Special is product that has been concentrated many resources of the company. In the current beer market, SABECO's beer products, specially is Saigon Special are competing directly with other strong competitors. Other competitors have invested a lot in IMC to develop their brand, so SABECO is trying to concentrate many resources for Saigon Special to win this market share. Moreover, the diversity in the beer market nowadays makes companies focus on branding, especially brand awareness to increase their position in the minds of consumers. Therefore, the main purpose of this study is review and analysis the quality of current IMC activities, which SABECO have done to build brand awareness for Saigon Special, and then give some recommendation to improve that IMC strategy.*

*The proposed research model was evaluated by using data collected from an online survey of over 200 participants (living in Ha Noi and Da Nang) and over 200 by offline method (Living in Ho Chi*

*Minh City). While the tests of internal consistency and validity indicate all scales being reliable and valid, results reveal that customer awareness toward Saigon Special is influenced by these activities: Advertising, Sale promotion, Direct marketing, Personal selling and Public relation. The research model is assessed by using SPSS to find out the level of influence of each factor and finally we will suggest some recommendation to improve the company's IMC strategy. By providing empirical evidence of consumer experience, the outcome of this study offers some recommendation about IMC activities to improve Saigon Special's brand awareness.*

## Keywords

*Integrated Marketing Communication, IMC, brand, brand awareness, Current situations marketing communication, SABECO, Saigon Special*

## I. INTRODUCTION

### 1.1. Introduction Saigon Special Beer

According to the official website of Saigon Special, nearly 20 years ago, when the Vietnamese economy started to integrate itself, the domestic beer market was still bored by local beer brands that were almost identical and included in fermented ingredients, from cereals. In fierce competition, the management of the Saigon beer was anxious to make a breakthrough decision. Saigon Special will open a new direction, more special and separate. Thanks to the most advanced production line in the area and traditional long-term fermentation, a unique taste, unique in the market was born. This bold and challenging step is a tacit acknowledgment that Vietnamese deserve a special "made in Vietnam" beer. And Saigon Special marks itself as the first Vietnamese premium beer, with outstanding quality and international standards. To assert its "personality", Saigon Special launched the bottle design low. It marked the distinct difference of Saigon Special among a large number of international and domestic beer brands using a typical high-end bottle. This special design, along with the slogan "You may not be tall but others have to look up" has inscribed Saigon Special brand into

the hearts of consumers nationwide. The people in favor of the product name “Saigon dwarf” to express the love for the brand. Saigon Special is regarded as a symbol of the breaking, modern, confident, but still humble and profound. Unique design with green color brings Saigon Special youthfulness, modernity in line with the spirit of the young generation of Vietnam is strong.

### 1.2. Research Question

Based on the context of Vietnam beer market in general and SABECO in particular, the main objectives of this study are to show and analyze the current situation of SABECO’s marketing communication programs for increase Saigon Special Brand Awareness and also giving recommendation for improving its IMC strategy to enhance Brand in fierce competition with other foreign and domestic competitors.

To solve the above mentioned problem, the question asked for this study was: *“What are the IMC’s tools which are needed to improve Saigon Special Brand Awareness?”*

### 1.3. Overview of Methodology

In this survey, research team will apply the quantitative method to achieve the aforementioned objectives. At the first, the researchers take an interviews with deputy of SABECO to take some information about current IMC situation of SABECO to orient research and scope the topic. Then combined with theoretical background model to build the questionnaire to find out what IMC’s tools are needed to increase the level of Saigon Special’s brand awareness.

About 500 samples have used to survey the beer consumers who are at the age of 18 years old and over. After collecting information, the necessary data will be analysis through the support of SPSS software.

## II. LITERATURE REVIEW

### 2.1. Integrated Marketing Communications (IMC)

#### 2.1.1. Definitions of IMC

“Marketing facilitates the exchange process and the development of relationships by carefully examining the need and want of customers, developing a product or service that satisfied these needs, offering it at a certain price, making it available through a particular place or channel of distributing and developing a program of promotion or communication to create awareness and interest” (Belch & Belch, 2007, p. 9). It has no doubt with marketing communication and promotional activities are important factors of any companies’ strategies due on product or service. This is necessary to communicate and inform the product information of feature and it benefits to the target customers (Ferrell & Hartline, 2008).

#### 2.1.2. Promotion Mix: Tools of IMC

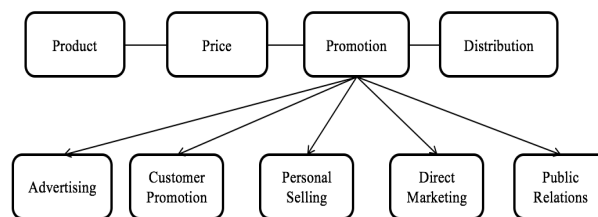

#### Promotion Mix: Tools of IMC

#### 2.1.3. The role of IMC

IMC goal is persuaded the customers perception and stimulate their behavior by using communication tools to communication its messages. It also builds a relationship between buyer and seller which it makes more efficient to increasing brand awareness (Ejebro, 2007). To follow the goal, objectives are intended to approach and convince target customers for purchasing of product or service that they perceived of information to make a company achieved the goal which gets the customers in contact.

Using IMC is a high benefit that provides the company a good image and move forward to run the product or service to the market because of the fast produced of product or service in nowadays. IMC can be used in simply or complex products which the main process to involving with customer needs (Gabrielsson & Johansson, 2002).

### 2.2. Brand Awareness

#### Definition of Brand Awareness

Brand awareness can be explained as the degree of consumers’ experience with a brand. Aker (1991) & Keller (1993) affirmed that brand awareness is a very important element of brand equity. Rossiter & Percy (1992) explain brand awareness as the ability of consumers to differentiate a brand amongst other brand. Keller in (1993) conceptualized brand awareness as comprise of brand recall and brand recognition. Keller (1993) said that “brand recognition may be more significant to the point that product decisions are to be made in the store”. Rossiter (1992) resulted that brand attitude and decision to purchase a product can only be urbanized through brand awareness.

### 2.3. Research Model

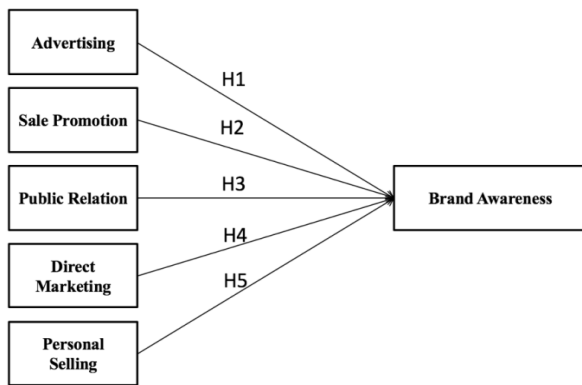

#### 2.3.1. Advertising

AD1 I can easily see the advertising videos of Saigon Special Beer in many places

AD2 I can easily see the advertising images of Saigon Special Beer in many channels.

AD3 I easily remember the name, color, and design of the Saigon Special beer when I saw it's advertising.

AD4 Advertising contents of Saigon Special beer brings young and modern people.

#### 2.3.2. Sales Promotion

SP1 It's easy for me to see sale promotion program of Saigon Special

SP2 Saigon Special has many types of sale promotion.

SP3 I think more about Saigon Special Brand when seeing its sale promotion programs.

SP4 Sale promotions of Saigon Special made me tend to switch to use its products.

#### 2.3.3. Public Relations

PR1 Saigon Special hold many Public Relation activities.

PR2 Public relations activities of Saigon Special build good relationship with me

PR3 Public Relations activities of Saigon Special increase my credibility with the brand.

PR4 Public Relations activities of Saigon Special make this brand to be famous.

#### 2.3.4. Direct Marketing

DM1 I often receive or see direct marketing activities of Saigon Special Beer.

DM2 I get more information about Saigon Special through it's direct marketing activities. DM3 I feel close to the Saigon Special Beer brand through direct marketing.

DM4 Direct Marketing of Saigon Special Beer is creative, engaging and interesting.

#### 2.3.5. Personal Selling

PS1 I see a lot of Personal Selling of Saigon Special Beer.

PS2 I get more information about Saigon Special through personal selling.

PS3 I have good impressions about the services of the Saigon Special's personal selling.

PS4 Personal selling leads me to believe to use Saigon Special.

#### 2.3.6. Brand Awareness

BR1 Saigon Special is famous and popular.

BR2 I easily distinguish Saigon Special from other beers.

BR3 I remember the color, shape and logo of Saigon Special.

BR4 I always think about Saigon Special first if I wanted to buy beer.

### 2.4. Hypothesis Development

H1: Advertising affects Saigon Special Beer Brand Awareness

H2: Sales affects Saigon Special Beer Brand Awareness

H3: Public affects Saigon Special Beer Brand Awareness

H4: Direct Marketing affects Saigon Special Beer Brand Awareness

H5: Personal Selling affects Saigon Special Beer Brand Awareness

## III. METHODOLOGY

### 3.1. Research Process

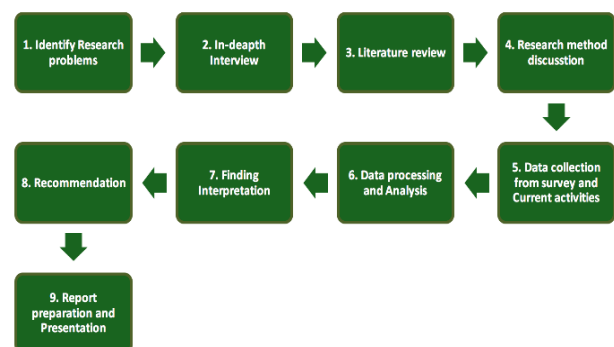

### Research Process

#### 3.2. Instrument and Questionnaire

##### 3.2.1. Scale measurement

In almost survey cases, measurement scale should be used to classify and quantify variables. Our survey used two measurement scales: ordinal scale and nominal scale. Ordinal scale allows respondents to show relative magnitude between the answers (Hair, et al., 2010) Nominal scale, which requires respondents to provide some type of descriptor as the raw response, is used in demographic questions (Hair et al., 2010).

##### 3.2.2. Questionnaire

One of the most widely used instruments for measuring preference, attitude, and opinion is Likert (1932) scale. It consists of a number of items with around 4 to 7 points or categories each. Lewis (1993) found that the mean difference of 7-point scales correlated more strongly than those of 5-point



scales with the observed significance levels of t-tests. According to Rob Johns (2010), Data from Likert items becomes significantly less accurate when the number of scale points drops below five or above seven. Moreover, Miller (1956) indicated that the human mind has a span of absolute judgment that can distinguish about seven distinct categories, a span of immediate memory for about seven items, and a period of attention that can encompass about six objects at a time, which recommended that any increase in number of response categories exceed seven might be ineffective.

From all the above research results, we use 7-point scales to collect the data. The scale expresses the intensity of respondents in each given item with the level of disagreement/agreement.

### 3.3. Sampling Design and Data Analysis Procedure

#### 3.3.1. Sample collection

**General Sample Characteristics:** General requirements for respondents are all over 18, living in Vietnam and reading Vietnamese. There is no distinction between gender and occupation.

#### 3.3.2. Data analysis procedure

After collecting all necessary data from the objects, began conducting the research and obtained:

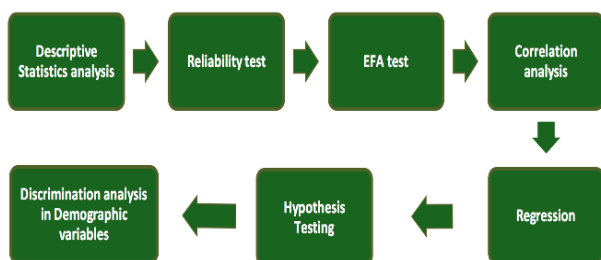

### Data analysis procedure

## IV. DATA ANALYSIS

### 4.1. Reliability Test

According to the result of reliability test from SPSS, we will see the column Corrected Item – Total Correlation. And if this value is smaller 0.3, it will be eliminated (according to Hair et al, 2010). We can see values of SP2 are lower than 0.3, so it will be eliminated run second time.

From the result of reliability test from SPSS second time, Advertising, Sale Promotion, Public Relation, Direct Marketing, Personal Selling and Brand Awareness all have the numbers of Cronbach's Alpha ( $\alpha$ ) of 0.813, 0.776, 0.799, 0.792, 0.815 and 0.813 respectively, showing that all dimensions have good reliability. In addition, Corrected Item-Total Correlation of every single item is higher than 0.3 that means no item has to be eliminated, and the Cronbach's alpha if each item is deleted is all lower than the Cronbach's alpha of the dimensions. This

result meets all standards of reliability. Thus, the next steps of measurement are able to be conducted.

### 4.2. Regression Analysis

Taking a look on the model summary table, the value of adjusted R Square is 0.719 that means 71.9% variation of dependent variable (SAT) can be explained by 5 independent variables (AD, PS, PR, SP, DM). In parallel, the Adjusted R Square is higher than 50% proving this research is statistically significant and the data is fitted to regression line. It means our research model is appropriate.

Basing on the ANOVA table, it is clear that Sig equal 0.000, less than 0.005 meaning that this regression model with 95% of credibility is consistent with the overall.

**Linear regression equation will be:**

$$BR = 0.418 * PS + 0.062 * SP + 0.514 * AD + 0.405 * PR$$

## V. FINDING AND RECOMMENDATION

### 5.1. Finding

After research and analyze data, we have clarified the research objectives.

**Finding 1:** Following this research, there are 4 tools which is influenced to Saigon Special Brand Awareness: Advertising, Personal Selling, Public Relation, Sale Promotion. Direct Marketing do not have significance in this researched model because the Sig value of the DM variable is greater than 0.05.

**Finding 2:** Saigon Special and Others Beer Brand in Vietnam are using 4 tools of IMC for building brand awareness: Advertising, Personal Selling, Public Relation, Sale Promotion. However, comparing with other brands, Saigon Special has not done it's IMC well, so Saigon Special need to improve it's IMC.

**Finding 3:** Tool "Advertising" is the strongest affect the level of brand awareness with Beta=0.514, next tool is "Personal Selling" with Beta= 0.418. Then tool "Public Relation" with Beta= 0.405. After that is tool "Sale Promotion" with Beta= 0.062. Therefore Saigon Special should allocate marketing resources in descending order: Advertising, Personal Selling, Public Relation, Sale Promotion.

**Finding 4:** Advertising on Internet, Discount, Organizing and sponsoring events and Salesman (PG) in restaurants are the best forms of marketing communication that correspond to four IMC tools: Advertising, Sale Promotion, Public Relation, and Personal Selling to increase the level of beer brand awareness in Vietnam.

### 5.2. Recommendation

#### 5.2.1. Advertising

##### Recommendation

According to our research, Saigon Special should focus on building Internet advertising, TVC and Fixed advertising signs.

A research of Hootsuite and We Are Social, there are 58 millions Facebook users in Vietnam in 2017 and total social media users in Vietnam increase 9 millions vs 2017, so social media, especially Facebook is a good channel for Internet advertising. Henieken's Vietnam Fanpage has 24 million followers while this number of Saigon Special is just 83 thousand followers (Source: Facebook). Therefore, Saigon Special should focus on creating viral video marketing, product images, creative content, building social network discussions to be more popular with Internet users. Taking advantage of online marketing platforms like Google, Facebook, Youtube, influencers to make the messages and images of Saigon Special reach many people. In addition, authors recommend Saigon Special should invest for TVC, creating TVCs with messages which bring the young, modern images of Saigon Special beer drinkers, choosing to broadcast in golden time to increase accessibility.

Fixed advertising signs such as banners, posters and billboards should be appeared more so that people can easily see the Saigon Special image anytime, anywhere. At the same time, Saigon Special can be connect with point of beer sale points to have better display than other beers.

#### **5.2.2. Personal Selling Recommendation**

Ho Chi Minh city is the biggest business city in Vietnam, it is also the big market for Saigon Special, so Saigon Special should focus more on this market, **increase the quantity of PG in Ho Chi Minh**. Sale Promotion is an effective tool to increase the level of brand awareness, but it also the tool which takes a big finance source (Interview). Therefore, Saigon Special should **balance resources so it can develop other IMC tools** to have a stronger IMC strategy, not just focus on Personal Selling.

Personal Selling in general and PGs in particular are also considered as the brand's representative, so any action of PG when serving customers will affect the brand in the mind of consumers. Therefore, Saigon Special should cooperate with companies specializing in providing PGs, the **PGs needs to be trained and understand clearly about the product** to avoid mistakes while working, and improve the level of Saigon Special Brand awareness in consumers' mind.

#### **5.2.3. Public Relation Recommendation**

Public Relation is a strong tool which influence the level of brand awareness, so Saigon Special really need to care about it. There are three activities which respondents choose like the best type of Public Relation to increase the level of beer brand

awareness in Vietnam: organizing and sponsoring sport and music, Sponsoring for TV shows, and Social activities.

Organizing and sponsoring sport and music event is chosen by the large number of respondents because they are activities which reach the consumer's want. Main consumers of Saigon Special is young, so they like exciting activities and music, sport represent the young and modern life. Their music festivals in the past were very successful, they attract a lot of young people and achieve good results. (Source: Interview). These events need to be planned in detail to avoid mistakes that affect the brand. The presence of celebrities is a necessity; the event needs to take full advantage of the fame of influencer on social network, and combination with Internet advertising, traditional advertising to increase the of events on every medium, from which to replicate event information and contribute to increasing brand awareness.

TV shows are a good investment option, and the company needs to connect with TV stations to be able to sponsor their programs. For Saigon Special, they should invest programs which must attract many young people because Saigon Special's target consumer are young people. Some shows Saigon Special need care for investment such as "The Voice", "Phiên Bản Hoàn Hảo", "Giọng Ải Giọng Ai", "Hát Mãi Ước Mơ", "Thần Tượng Tương Lai" because according to research of You Net Media, these shows are in Top 10 most prominent TV shows in Vietnam in 2017. Through these shows, brand names as well as logos will easily go into the minds of customers, this is an effective way to increase consumer's awareness of Saigon Special.

Social contribution likes charity, donation, etc. was chosen as the most effective Public Relation for beer brand awareness in Vietnam by nearly 15% of respondents. Saigon Special does not have to invest too much in this activity, but they should not skip it. Creating a social activity that has its own highlight and periodicity is a good idea for Saigon Special. They will not be confused with other brands's activities as well as building a better brand in consumer's mind 5.2.4. Sale Promotion

#### **5.2.4. Sale Promotion Recommendation**

With the purpose of increasing the level of brand awareness of Saigon Special, SABECO does not need to spend too much resources to do Sale Promotion activities, it does not mean not organizing any Sale Promotion activities. For doing effective Sale Promotion, Saigon Special should focus on doing "Discount" and "Giving Gift". The authors recommend that Saigon Special just should have

sale promotion in special occasions such as Tet holiday, or other big holidays in Vietnam. Because this is time which the demand for beer increases rapidly, if consumers can see sale promotion of Saigon Special in point of sale such as supermarkets, restaurant or stores,... it will make them increase the level of Saigon Special brand awareness. The classic research done by Dobson, Tybout and Sternal (1978) argued that use of promotion decrease the brand evaluation, so marketer of Saigon Special need be smart when choose what types of Sale Promotion to increase this brand awareness.

#### 5.2.5. Conclusion Recommendation

At present, Saigon Special is doing exactly the marketing activities that the beer market needs to increase the level of brand awareness. However, they have not done enough and have not been effective enough for each IMC tool. Therefore, the author's recommendations are to increase the frequency and effectiveness of the activities of each of these tools, and smartly select the appropriate types to avoid having any negative impact on the brand.

In addition, according to Mr. Phuc, a very important thing which could be the key to solve all problem in Saigon Special IMC's strategy is human resources. Saigon Special should invest more human resources for marketing, recruiting more marketers, improving quality of marketers and building the marketing team as strong as possible. At present, Saigon Special surely know the importance of integrated marketing communication and marketers.

#### REFERENCES

- Aaker, D. A. (1991). *Managing Brand Equity*. The Free Press, New York
- Aaker, D. A. (1991): *Managing Brand Equity: Capitalizing on the Value of a Brand Name*. Free Press, New York
- Aaker, D., & Keller, K. L. (1990). Consumer evaluation of brand extension. *Journal of Marketing*. Admin. (May 2018). Using Direct Marketing to Create Awareness and Growth for Businesses, Brand Now.  
<http://www.brandnow.asia/using-direct-marketing-to-create-awareness-and-growth-for-businesses/>
- Aleamoni, L. M. (1976). The relation of sample size to the number of variables in using factor analysis techniques.
- Anderson, R. E. & Dubinsky, A. (2003). *Personal Selling: Achieving Customer Satisfaction and Loyalty*. Kogan Page Limited. UK.
- Andrew, R. (2003). *Research Questions: Continuum* International Publishing Group. New York.

Armstrong, G., & Kotler, P. (2005). *Marketing: An Introduction* (7th ed.). New Jersey.

Available online:

<http://pareonline.net/getvn.asp?v=10&n=7>

Axelsson, D., & Nordberg, H. (2005). *The Role of RP, in the introduction Stage of a New Brand*. Master's Thesis within Business Administration. Jönköping University.

Baker, M. J, 2003, *The Marketing book*, 5th edition, Butterworth-Heinemann, MA

Barrett, P. T., & Kline, P. (1981). The observation to variable ratio in factor analysis. *Personality study and group behavior*, 1, 23-33.

Belch, G. E. & Belch, M.A. (2007). *Advertising and Promotion, An Integrated Marketing Communications Perspective*. 9th.ed. McGraw-Hill/Irwin. USA.

BiaSaiGon Facebook fanpage. (2017). Saigon Special – True Love

# Analyzing the Difference in Service Quality Between Local and International Banks in Vietnam

**Doan Thi Thanh Giang**  
FPT University  
HCMC, Viet Nam

**Duong Huynh Thao Nguyen**  
FPT University  
HCMC, Viet Nam

**Hoang Phuong Anh**  
FPT University  
HCMC, Viet Nam

**Vo Van Thanh Nhat**  
FPT University  
HCMC, Viet Nam

**Le Thu Huyen**  
FPT University  
HCMC, Viet Nam

## Abstract

The increased use of banking in Vietnam has led to a number of improvements by banks to improve service quality. This has provided customers the opportunity to choose a bank that offers services that satisfy them. Therefore, the main purpose of the report is to analyze customer perceptions of the difference in service quality between domestic and international banks in Vietnam, using the SERVPERF model. Research using quantitative methods (survey). In addition, the five aspects of service quality are: tangible, reliability, responsiveness, empathy and assurance are considered as variables for this. This has a look at using two forms of data collection: primary data and secondary data. 400 samples collected during the data collection process were limited in Ho Chi Minh City and have experience both local and foreign banks, 378 valid samples and associated secondary data from the related exams and statistical reports. SPSS software is used to process collected data. The results of the study showed the difference in service quality between the two banks and the purpose of the study is achieved. Researchers have given some advices to help banks improve their service quality and gained high evaluating from their consumers.

## Keywords

Service Quality, Local Bank, International Bank

## I. INTRODUCTION

### 1.1. Background

According to brand consulting Mibrand Vietnam - a partner of Brand Finance - published the Brand Beat Score Vietnam Bank Report 2017 - a report on the efficiency of brand communication in the banking sector of Vietnam in 2017. Based on the results, Vietcombank was the local bank with the largest brand awareness index of 40.77% and the leading brand awareness index of foreign banks was HSBC with 8.3%. Mibrand's "Brand Beat Score Banking Sector 2017" survey was based on an online survey of nearly 1000 samples for consumers who above 18 years old in six big cities in Vietnam (Hanoi, Ho

Chi Minh City, Da Nang, Can Tho, Hai Phong, Nha Trang). This is the reason why the authors chose Vietcombank and HSBC as the representatives of local and international banks to analyze the difference in service quality.

### 1.1.1. Overview of Vietcombank (VCB)

Based on VCB's own introduction, Vietcombank (Joint Stock Commercial Bank for Foreign Trade of Vietnam) was the first state-owned commercial bank chosen toward that administration on pilot privatization by the Government. Beginning from an extremely special bank specialized for foreign exchange, VCB has turned into a multi-utilitarian bank. VCB is a standout amongst those biggest business banks in Vietnam and it operates both foreign and domestics.

### 1.1.2. Overview of HSBC

Based on HSBC's own introduction, early 2009, HSBC became first foreign bank established subsidiary in Vietnam. HSBC Vietnam owned 100% capital by Hongkong and Shanghai banks. With 150 years of experience in the Vietnamese market, HSBC offers full financial banking services.

### 1.2. Research objectives and research questions

This study includes three main purposes:

- To identify the different perception in service quality in local and international banks in Vietnam.
- To determine the effect of different demographics to perceived service quality in banking industry.
- To give some suggestions for the problems of local and international banks.

To gain the objectives, this study needs to clarify three questions:

- What is the different perception of service quality between local and international banks in Vietnam?
- What do different demographics affect to perceived service quality in banking industry?
- What are suggestions for the problems of local and international banks?



## II. LITERATURE REVIEW

Following that, this part will present the basic facts of the theory is possibly associated with the issue of service throughout the banking system quality.

### 2.1. Service

According to Heizer and Render (1999), services created intangible products such as financial, food, entertainment, insurance, transportation, trade, government, real estate, medical and services were maintained like occupations.

### 2.2. Service quality

Service quality is clarified as the rank of disagreement between customers' standard expectations for service and their experience of service performance (Parasuraman et al., 1985). In addition, service quality is considered as a comment success factor for organizations to distinguish from the others. Many researchers have been conducted to determine the factors of service quality.

### 2.3. Service quality in bank

The competitive advantages can be created by the consumer service. For the bank, in order to reach a great level of service quality, the bank's presenters tend to orient the service to customers. The customers who have most interactions with the bank and the bank have responsibility for keeping customers satisfaction. There are different elements of customer services in banks and they are regulated by the presenter of banks (Richardson and Robinson, 1986).

### 2.4. Service quality measurement

The SERVQUAL model was developed by Parasuraman, Berry and Zeithaml (1985, 1988). According to SERVQUAL model, the level of service quality is expressed by the distance between cognitive and expected services and based on five service quality dimensions, namely tangibles, reliability, responsiveness, assurance, and empathy. The model has 22 items to assess customers' perceptions and expectations about service quality. However, the use of quality models and distances as a basis for assessing quality of service is controversial (Carmen, 1990; Babakus & Boller, 1992; Cronin & Taylor, 1992).

Based on various conceptualizations and activities, many researchers have criticized the limited effect of the SERVQUAL model as a means to understand customer satisfaction and loyalty. Cronin and Taylor (1992) found that the conceptual basis of the SERVQUAL scale could not accurately determine the totality of customer satisfaction and suggested the SERVPERF scale. According to the SERVPERF model: Quality of Service = Perceived Level. The SERVPERF scale also uses 22 items like the customer's query in the SERVQUAL model,

ignoring expectations. The SERVPERF model was tested in four industries (dry cleaning, banking, pest control, and fast food) and it has a great fit in all four industries and it only contains half of the items to be measured. These results are interpreted as complementary support to the superiority of the SERVPERF approach to service quality measurement.

This study uses SERVPERF to measure the quality of banking services based on customer perceptions of the services they have experienced.

### 2.5. Perceived service quality

Yoo and Park (2007) described that employees as a substantial contribution in enhancing perceived service quality. Likewise, O'Neill và Palmer (2003) related that perceptions service quality of customers may be affected by the standard of their previous experience with a specific service. According to Richardson and Robinson (1986), the first thing that affect to customer's perceived service quality of bank is when the staffs in the bank have a good connect with the clients, this is the key element when supplying the customer service. Negi (2009) pointed out that perceived service quality of customers has been greatly enhanced by its specific contribution to business competitive, customer satisfaction and loyalty. This makes quality service a very important criterion for businesses. They must know how to measure and make the necessary improvements in aspects of quality of service.

### 2.6. Related researches

### 2.7. Framework model

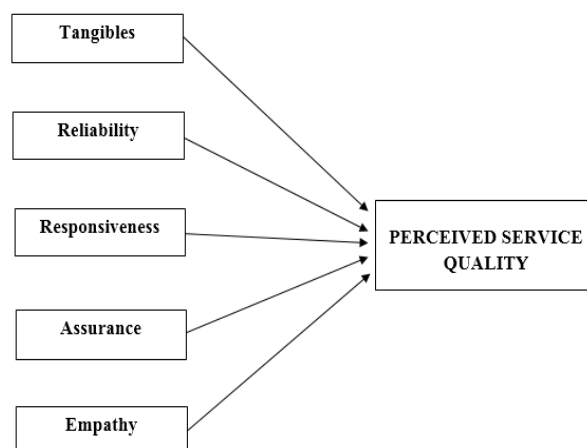

#### Perception model

(Source: Cronin and Taylor, 1992)

### 2.8. Hypothesis

H1: There is a positive relationship between tangible and customer perception.

H2: There is a positive relationship between reliability and customer perception.

H3: There is a positive relationship between responsiveness and customer perception.

H4: There is a positive relationship between assurance and customer perception.

H5: There is a positive relationship between empathy and customer perception.

### III. METHODOLOGY

#### 3.1. Research method

##### 3.1.1. Quantitative method

Quantitative research is a method of research that uses to process data. Data is numbers and anything that can be systematically measured to investigate phenomena and their relationships. According to Leedy (1993), quantitative methods are used to answer the relationship questions in measurable variables with the intent to explain, predict and control a phenomenon. Quantitative methods are started with data collection based on hypothesis or theory and it is followed by application that describes or reasoned statistics. The general objective of a quantitative study is to classify features, count them, and construct statistical models in an attempt to explain what is observed.

##### 3.1.2. Qualitative method

Qualitative research is a qualitative method of collecting data from audiotapes, videotapes, and field notes. Qualitative research is particularly effective in gathering information on the values, opinions, behaviors, and social contexts of specific populations. With the qualitative method, the question structure used is opened - question (Creswell, 2003). According to Minichiello et al. (1990), after completing the collection of answers, the researchers will translate those answers in their own language.

#### 3.2. Pre-testing

Participants in pre-testing: a small group of subjects included in the research sample of the study. Small groups are aged 18 and over and have experienced the services of the two research banks HSBC and VCB. The number of participants is 30 people.

##### • Result of pre-testing:

After running Cronbach's Alpha for each factor, the results are shown in the tables below.

Factors	Cronbach's Alpha
TAN	0.878
REL	0.868
RES	0.848
ASS	0.918
EMP	0.798
PSQ	0.903

**Table 4. 1 Cronbach's Alpha for the pre-testing**

(Source: authors)

Based on table 4.1, all factors are reliable since Alpha conditions  $> 0.6$ . However, when testing the

reliability of REL, it was found that if the REL4 scale was removed, the REL's Alpha increased to 0.868 ( $> 0.773$ ) and Corrected Item Total Correlation of REL4  $< 0.3$ , so REL4 was removed to increase reliability of the scale.

After the pre-testing, the study was removed and added some scales that are more suitable to evaluate the service quality of Vietcombank and HSBC Vietnam.

### IV. DATA ANALYSES

This part describes the collected data analysis. It includes the data descriptive, demographic discriminant, reliability test, exploratory factor analysis (EFA), correlation analysis, multiple linear regression analysis and the hypothesis testing. After analyzing data be collected from the survey, researchers can accept or reject the hypothesis proposed in chapter two to validate the factors that affect customer's perceived service quality in VCB and HSBC.

#### 4.1. Data preparation

The authors proceed a quantitative survey in the lobbies of HSBC and collected 400 surveys, but it is only 378 valid samples to analyze data and evaluate service quality in banks.

#### 4.2. Descriptive statistic

Descriptive statistics for variables describe the answers in nominal scale among observed variables. In this section, the author uses questions to understand the details of the assessment and the needs of the customer using the service for each factor.

#### 4.3. Cronbach's Alpha test

The Cronbach's alpha of 6 factors are all greater than 0.6. However, the Corrected Item-Total Correlation of TAN4, TAN5, EMP3 in the questionnaire are less than 0.3, so they are removed. Other items have the Corrected Item-Total Correlation greater than 0.3, so they are accepted and appropriate to include the next step.

#### 4.4. Exploratory factor analysis

##### 4.4.1. Independent variables

KMO coefficient and Sig. of Bartlett's Test are acceptable, indicating that 18 items are correlated and entirely consistent with the factor analysis. Rotation Sums of Squared Loadings is high 66.464%. Thus, the five factors represent 18 observed variables can explain 66.464% of the explanation of all 18 observed variables. Moreover, Rotated component matrix in exploratory factor analysis provides information on factor loading of the variables of the scale. Factor loading must be greater than 0.5. 18 observed variables have factor loading greater than 0.5; so, they are retained to evaluate the quality of service and accepted for convergence.

#### 4.4.2. Dependent variable

5 variables were grouped into one factor. Exploratory factor analysis with standard of Eigenvalue > 1 has 5 components extracted by Eigenvalue of 3.174. These components explain 63.472% variance of data, KMO coefficient is 0.829 > 0.5 is acceptable for compliance. Varimax rotation method is used to explain the matrix of factors. The table Component Matrix indicates that all factor loadings are above 0.5 and accepted for convergence.

#### 4.5. Correlation analysis

The independent variables and dependent variable are related, and they are distinctive value. The correlation is significant at the 0.01 level (2-tailed). Therefore, these variables are suitable to analyze regression.

#### 4.6. Multiple linear regression

Adjusted R Square reflects the degree of influence of independent variables on dependent variable. In the VCB's model, the Adjusted R-Square is 0.689 that means 5 independent variables affect 68.9% of change of dependent variable. In the HSBC's model, the Adjusted R-Square is 0.703, 5 independent variables affect to 70.3% of change of dependent variable. As a result, the influence level of the HSBC's model is higher than VCB's model. In addition, the models do not occur autocorrelation phenomenon (D of VCB = 1.505 and D of HSBC = 1.738) and the multiple linear regression models are consistent with the data set and can be used for generalization (Sig. of F test < 0.05).

Based on the results of regression coefficient, Sig. value of t test is < 0.05, meaning that the 5 independent variables are significant in 2 models. Besides that, VIF is very small (less than 10), indicating that these independent variables are not closely related to each other so there are no multipliers. A regression equation for the model can be written using the Unstandardized coefficients (B) in table 4.7 as following:

$$PSQ(VCB) = - 0.743 + 0.234TAN + 0.276REL + 0.184RES + 0.247ASS + 0.253EMP$$

$$PSQ(HSBC) = -0.880 + 0.305TAN + 0.208REL + 0.221RES + 0.311ASS + 0.187EMP$$

According to standardized beta values ( $\beta$ ), there are 5 independent variables contributed to dependent variable (PSQ). In VCB's model, the most important and strongest factor is REL with the highest beta ( $\beta = 0.311$ ) and in HSBC's model, the strongest factor is ASS with the highest beta ( $\beta = 0.304$ ).

However, standardized beta coefficients only indicate the order that independent variables impact on dependent variable. To evaluate service quality of these banks, we consider the mean of items

according to Likert 5-point scale. As a result, the customer perception of the service quality of HSBC is better than VCB.

#### 4.7. Hypothesis testing

Based on the result of regression coefficient, there are 5 factors that affect to perceived service quality and they are have positive relationship.

#### Discriminant analysis for demographic

There is the difference among demographic (gender, age, job, education and income) in perceived service quality.

##### 4.7.1. Age

For VCB, the older evaluate service quality of VCB lower than the younger, the average of service quality evaluation of the 18-20 years old customers are the highest value. In contrast, for HSBC, the average of service quality evaluation of the 21-29 years old customers is the highest value, then over 50 years old people.

##### 4.7.2. Gender

Mean of HSBC's service quality is higher than VCB's (3.82 > 3.75). Moreover, male customers evaluate service quality (both of two banks) is greater than female customers do.

##### 4.7.3. Education level

For VCB, the customers studied Intermediate or College level have the highest average of service quality evaluation but the people graduated Postgraduate Level have the lowest average of service quality evaluation. On the other hand, the customers have postgraduate level evaluate the highest average of HSBC's service quality. Therefore, customers who have high education level evaluate the service quality of HSBC better than VCB.

##### 4.7.4. Job

The business has the highest average of HSBC's service quality evaluation while students and employees have the highest average of Vietcombank's service quality evaluation.

##### 4.7.5. Income

The customers who have high income evaluate HSBC's service quality better than people have low income. On the other hand, the customer who have low income evaluate Vietcombank's service quality better than people has high income. This is the special difference between HSBC and Vietcombank.

## V. KEY FINDINGS AND

### RECOMMENDATIONS

#### 5.1. Key findings

After analyzing, the authors answer the research questions and gain research objectives. This research analyzes the difference in service quality between local and international banks in Vietnam.

Finding 1: the reliability factor has the greatest



impact on the quality of service being perceived by customers in local banks and the assurance element strongly influences the perceived service quality of international banks.

Finding 2: there are different perceptions of service quality in difference demographic (gender, age, education level, job and income).

Finding 3: most of the problems of domestic and international banks are ATMs, bank staff's attitude, security and operating time. Based on the result of the study and respondents' ideas, we have some recommendations for the banks to improve service quality and get more customers' agreement.

### 5.2. Recommendations

As a result, local and international banks often check the operation of ATMs, especially ATMs in crowded places. Staff needs to be checked about the ability to serve regularly to ensure service quality to customers. Security should be paid more attention by equipping modern equipment and software. In addition, the operating time of banks should also be adjusted to facilitate the transaction customers.

### 5.3. Limitation of research project

The length of the questionnaire made it difficult for the respondents to make a mistake and made them feel impatient to answer all the questions. This makes it difficult to collect data and takes more time to explain the question so that the respondent can give a clear and reasonable answer. Limited in time, resources and finance, the survey was conducted in Ho Chi Minh City only. Due to limitations, the size of the sample and the number of questionnaires (400 questionnaires) were not large enough. Therefore, the research team found it difficult to generalize the results. If more cities and provinces can be surveyed, the results will be more reliable. Secondary data on service quality assessment of Vietcombank and HSBC Vietnam does not have much publicity, so it makes it difficult for the research team to collect data to produce a good research result.

## REFERENCES

- Abednego Feehi Okoe, J. S. A. & A. O., 2013. *Service Quality in the Banking Sector in Ghana*. Canada: Canadian Center of Science and Education.
- Carmen, J., 1990. Consumer Perception Service Quality: An Assessment Of SERVQUAL Dimensions. *Journal of Retailing*, 66(1), pp. 33-35.
- Cronin, J. J. & T. S. A., 1992. Measuring Service Quality: A Reexamination and Extension. *Journal of Marketing*, 56(7), pp. 55-68.
- Dijana Mečev, I. K. G., 2015. *Primary healthcare service quality measurement: Servqual scale*.

Croatia: Preliminary communication.

- Edvardsson, B., 2005. Service quality: Beyond cognitive assessment. *Managing Service Quality*, 15(2), pp. 127-131.
- Heizer, J. R. B., 1999. *Operations Management*. 5th ed. Upper Saddle River, NJ: Prentice-Hall.
- HSBC, 2018. *HSBC*. [Online] Available at: <http://www.about.hsbc.com.vn/vi-vn/hsbc-in-vietnam> [Accessed 13 6 2018].
- John W. Creswell, V. L. P. C. M. L. G. W. E. H., 2003. Advanced mixed methods research designs. In: C. T. Abbas Tashakkori, ed. *Handbook of Mixed Methods in Social & Behavioral Research*. London: SAGE publications, pp. 209-240.
- Kumar, M. T. K. F. & C. V., 2010. Comparative evaluation of critical factors in delivering service quality of banks: An application of dominance analysis in modified SERVQUAL model. *International Journal of Quality & Reliability Management*, 27(3), pp. 351-377.
- Leedy, P. D., 1993. *Practical research: planning and design*. New Jersey: Prentice-Hall.
- Negi, R., 2009. Determining customer satisfaction through perceived service quality: A study of Ethiopian mobile users. *International Journal of Mobile Marketing*, 4(1), pp. 31-38 .
- O'Neill, M. a. A. P., 2003. An exploratory study of the effects of experience in consumer perceptions of the service quality conduct. *Managing Service Quality*, 13(2), pp. 187-196.
- Parasuraman A., Z. V. A. & B. L. L., 1985. A conceptual model of service quality and its implications for future research. *Journal of Marketing*, Volume 49, pp. 41-50.
- Parasuraman A, V. A. Z. a. L. L. B., 1988. SERVQUAL: A Multiple-Item Scale for Measuring Consumer Perceptions of Service Quality. *Journal of Retailing*, 64(1), pp. 12-40.
- Richardson, B. A. & G. R. C., 1986. The impact of internal marketing on customer service in a retail bank. *International Journal of Bank Marketing*, 4(5), pp. 3-30.
- Soleyman Iranzadeh, F. C., 2011. *Service Quality Dimensions in the Banking Industry and Its Effect on Customer Satisfaction*. London: IntechOpen.
- Taylor, R. B. a. S. J., 1975. Introduction to qualitative research methods. *Journal of Contemporary Ethnography*, 6(2), pp. 241-243.
- Vietcombank, 2018. *Company presentation*. Vietnam, Vietcombank.

VIR, 2017. *Viet Capital Securities*. [Online] Available at: <https://www.vcsc.com.vn/tin-chi-tiet/standard-chartered-anz-and-citibanks-brand-score-at-the-bottom-of-the-list/181464> [Accessed 4 6 2018].

Yoo, D. K. J. A. P., 2007. Perceived service quality: Analyzing relationships among employees, customers and financial performance. *International Journal of Quality & Reliability Management*, 21(9), pp. 908-926.

# Analyzing the Relationship of Ethnocentrism, Animosity and Nostalgia on Vietnamese Household Purchasing Decision: A Case Study of Chinese Imported Goods

**Huynh Gia Thuy**

FPT University  
HCMC, Viet Nam

**Pham Tien Tung**

FPT University  
HCMC, Viet Nam

**Tran Hong  
Ngoc Thuy**

FPT University  
HCMC, Viet Nam

**Nguyen Huu  
Minh Tam**

FPT University  
HCMC, Viet Nam

**Nguyen Quang Hai**

FPT University  
HCMC, Viet Nam

## Abstract

*In recent years the relationship between Vietnam and China have been ever increasingly tense due to multiple conflicts and scandals, as well as the dispute over ownership of land. In particular, has garnered the animosity of Vietnamese people towards Chinese products all over media, kick-starting a massive wave of ethnocentric tendency all over the country. Because of these factors, we have decided to take a look into whether or not the newly fanned Animosity, as well as the wave of Ethnocentrism affects how the ordinary Vietnamese people buy household products. Furthermore, the research looks into whether or not Nostalgia is still an effective angle to tackle for marketing strategies within this period. Through the use of multiple means of quantitative and qualitative research methods, being questionnaires, household spending-tracking, and personal interviews, the research has put out quite unexpected results. Ethnocentrism and Animosity seem to no longer affect purchase decisions as much compare to previous studies. Nostalgia is determined to be still an effective marketing strategy that companies should use. While the research was small-scaled due to lack of personnel, it was conducted in the two largest cities of Vietnam and accurately depicts the mentality of its people. Although we have also found that perspectives and decision making is not uniform, thus getting an accurate picture of the whole country situation require more research.*

## Keywords

*Consumer Behaviour, Consumer Psychology, Household Purchase Decision, Consumer Ethnocentrism, Consumer Animosity, Consumer Nostalgia*

## I. INTRODUCTION

### 1.1. Background

China is the main partner of Vietnam for import goods with import value reached 58.229 billion of US dollar. Accounts for 27.6% of Vietnam's total import value in 2017 (General Department of Customs, 2018). However, with the relationship with China from the past until now, it has formed a

negative attitude toward Chinese product. Especially, with the South China Sea dispute issue, the more China becomes assertive in the South China Sea. It has established some emotion element named as ethnocentrism, animosity, and nostalgia, have been adopted in earlier studies as a construct for predicting consumer behaviors in different circumstances. Thus, understand the way those factor effect to the psychology of Vietnamese is necessary.

### 1.2. Problem statement

Under Anti-China campaign circumstances, household purchase decision becomes more difficult to understand and predict. Although there are some researches on Ethnocentrism, Animosity and Nostalgia has been researched in many different contexts and countries, but there remain various issues to be clarified in Vietnamese contexts.

### 1.3. Research objectives

The purpose of this study is to examine how ethnocentrism, animosity and nostalgia impact on Vietnamese household when they purchase a foreign product. Our objectives are as follows:

To understand the meaning of ethnocentrism, nostalgia, and animosity in Marketing.

To find out the effect of ethnocentrism, animosity, and nostalgia on the purchasing decision of households.

To analyze Vietnamese consumer behavior on Chinese imported goods in the current context.

To determine the practical implications for marketing and international business managers.

### 1.4. Research questions

To solve the research's objectives, the following questions need to be clarified:

What is Ethnocentrism, Animosity and Nostalgia in marketing?

How Ethnocentrism, Nostalgia and Animosity affect Vietnamese household's decision on purchasing Chinese imported product?

What is Vietnamese household's behavior when purchasing Chinese imported good?

What is the practical implications for marketing and international business manager?

## II. LITERATURE REVIEW

### 2.1. Background definition

#### 2.1.1. Consumer Ethnocentrism

Ethnocentric Consumer is a belief held by consumers on the appropriateness and indeed morality of purchasing foreign-made product (Shimp and Sharma, 1987)

#### 2.1.2. Consumer Animosity

Animosity as the negative attitudes or the antipathy of the members of one nation towards other countries which related to military, political or economic conflict whether they occurred in the pass or are happening. (Klein et al, 1998).

#### 2.1.3. Nostalgia

A preference (general liking, positive attitude, or favorable affect) towards objects that were more common in the past (Klein et al, 1998).

#### 2.1.4. Household

Household consists of one or more people who live under the same roof, both related and unrelated, who could be count a housing unit (Holbrook and Schindler, 1991).

In this research will consider household purchase decision process as the consumer decision perspective. In 1910, John Dewey introduce five same stage of consumer purchase decision which included need/problem recognition, information search, evaluation of alternatives, purchase decision, and post-purchase behavior like the figure 2.1.

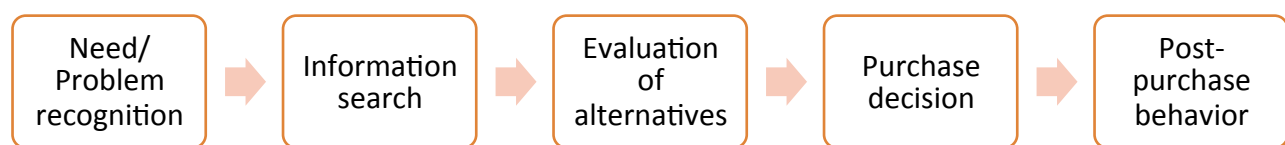

**Figure 2.1: A buyer's decision-making process**

(Source: John Dewey, 1910)

#### 2.1.5. Imported products

Imported goods are products brought into a national border, from an external source (Joshi, 2009).

#### 2.2. Related research

*"The animosity model of foreign product purchase: An empirical test in the People's Republic of China"* (Jill Gabrielle Klein & Richard Ettenson & Marlene D. Morris, 1998).

In 1998, Klein, Ettenson, and Morris introduced a model which examined the potential impact on foreign product purchase. The theory shows that consumer animosity has a direct negative effect on consumers' purchase behavior in the international markets. It means if consumers have feelings of animosity against specific nations or regions, the willingness to buy the specific nation's products or services would not only be influenced by the product performance itself but also be affected by the personal animosity towards the specific nations.

*"Consumer Ethnocentrism: Construction and Validation of the CETSCALE"* (T. A. Shimp & S. Sharma, 1987).

According to Shimp and Sharma (1987), CETSCALE (Consumer Ethnocentric Tendencies scale) is a measurement method to serve the study on consumer ethnocentrism. CETSCALE has been used in several studies with different contexts, from China, Russia to Turkey and Czech Republic (Balabanis et al., 2001; Klein et al., 2006). Most findings are the inverse links of the CETSCALE score and consumers' behavior in foreign-made products,

judgment, willingness or intention to purchase, for example (Shimp and Sharma, 1987; Netemayer et al., 1991; Sharma et al., 1995). The higher the score, the more ethnocentric consumer would be, and the higher the tendency they are averse to imported products (Shimp and Sharma, 1987).

*"Consumer Ethnocentrism: A test of antecedents and moderators"* (Sharma, S., Shimp T., Shin J. 1995).

After the research about consumer ethnocentrism in 1987, Sharma had done another research about that field in 1995 which about a test of antecedents and moderators consumer ethnocentrism. These papers identify theoretical antecedents of consumer ethnocentricity and the effect ethnocentricity has on evaluations toward foreign-made products.

*"Nostalgia and Consumption Preferences: Some Emerging Patterns of Consumer Tastes"* (Morris B. Holbrook, 1993).

This paper provides a brief preview of some work in progress on the phenomenon of nostalgia in consumer behavior. Holbrook developed "Nostalgia Index" to measure the psychographic variable, "nostalgia proneness" and influences preferences for products of the past was empirically supported.

*"Nostalgia Drives Donations: The Power of Charitable Appeals Based on Emotions and Intentions"* (Ford & Merchant, 2010).

In 2010, Ford and Merchant released paper research which includes three examinations about the way nostalgia impact on people intention. With the



category of charity donate intention, the analysis showed that evoke personal nostalgia will have a positive effect on the charitable-donation intentions of consumers.

*"Theory of Reasoned Action"* (Fishbein & Ajzen, 1975).

Fishbein and Ajzen in 1975 introduced the theory of reasoned action (TRA), which analyzed how the attitude affects behavior. TRA model also shows behavior is determined by the intention of that behavior. The two main factors that affect the intention are personal attitudes and subjective norms.

### 2.3. Proposed research framework

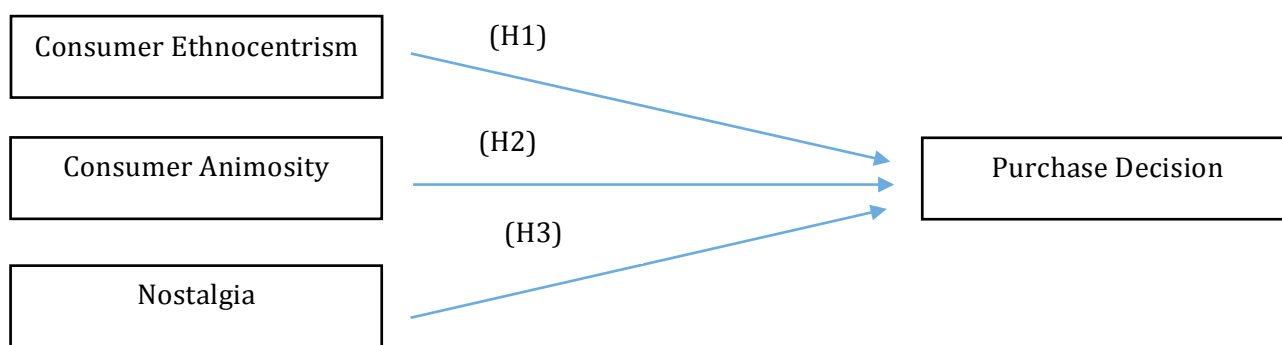

**Figure 2.2: Theoretical Framework**

(Source: Adopted and Adapted from Previous Studies)

### 2.4. Hypothesis development

Hypothesis 1: There is a negative relationship between ethnocentrism and purchase decision.

Hypothesis 2: There is a negative relationship between animosity and purchase decision.

Hypothesis 3: There is a positive relationship between Nostalgia and purchase decision.

## III. METHODOLOGY

The goal of this section is to describe and explain research approach as well as the research process. The research process happens in six step. First of all, clarify the research's objectives, targets, and purposes. Then, the literature review step will be mentioned to provide the relevant theories. After which we constructed the questionnaire and research scale. Then, our group use two methods to get data which is the qualitative method and quantitative method. The next step is filtered and encoded the data and using program Statistical Package for the Social Sciences (SPSS) version 2.0 to test the hypotheses and clarifying the relationship between factors of the model through various kinds of analysis. Finally, the result will be written in a report form.

*"Decision Making within the Household"* (Harry L. Davis, 1976).

The research prioritizes exploring how families make decisions rather than simply who is involved. The ongoing nature of family relationships, the inter-relatedness of their consumer choices, and the financial and time constraints faced by the family define a unique decision environment.

*"The trend of Vietnamese household size in recent years"*, (Nguyen Thanh Binh, 2011).

The research found that Vietnamese household size is decreasing gradually and the rate of single household rise from 4.22% (1999) to 7.24%. The household size will decrease more in the future and the trend is the nuclear family.

### 3.1. Research Metho

#### 3.1.1. Qualitative research

Marshall and Rossman (1999) describe that qualitative research is a descriptive and explanatory approach to explore a more in-depth understanding of the experience, motivation, perception of human behavior. According to Crandell (2011), qualitative research is the research method that collects data in the qualitative form such as document, image or information not measured by data.

#### 3.1.2. Interview

Also, the interview is the conducting intensive individual interviews with a small number of respondents to find out their perspectives on a particular issue or situation (Boyce et al., 2006). In this report, we will do the structured interviews which are the process that consists of a series of pre-determined questions that all interviewees answer in the same order. Then with the answers from the participant's researcher can compare and contrast different answers given to the same questions. The authors opens the interviews with nine households include in Ho Chi Minh City and Ha Noi city. The meeting is implemented in two days, 16th and 17th June 2018. Each interview lasts 5 minutes.



### 3.1.3. Collected Bill

The authors collect data from 4 household including in Ho Chi Minh City. We will ask the household receipts of a month which from 13th June to 13th July. This data is collected to analyze the purchase action of household and support for the quantitative data in the recommendation part.

### 3.1.4. Quantitative Research

Malhotra (2012) describe quantitative research is a research method that collects data in the quantitative form. This report uses quantitative research methods to analyze the relationship between household purchase decision and three factors including ethnocentrism, animosity, and nostalgia. The survey was conducted by offline and online interview through the questionnaire, and the total of respondents is 354.

Collection time: from 13th June to 13th July 2018

Collection place: Vincom Mart Cong Hoa Supermarket, Pham Van Hai Market, BigC Mien Dong Supermarket, Aeonmall Tan Phu.

## IV. DATA ANALYSIS AND FINDINGS

### 4.1. Data descriptive analysis

#### 4.1.1. Qualitative Data

##### Interview

The interview happen with 9 households, consisting of 16 people in total. In general, the number of household care about the origin is taken over the highest percentage which is 55.5%. Ethnocentrism does exist in 8 out of 16 of the respondents however they claim it doesn't affect their purchase decision. All 16 respondents claim having Animosity towards China, but only 7 respondents say that it affect them, while the other 9 claim that it does not affect whether or not they will buy Chinese product. As a result, we conclude animosity exists scarcely in the household and does not affect the purchase decision of household. There are two people said that nostalgia affects their purchase decision while the rest does not care about the nostalgia.

##### Bill

The bill is collected from 13 June to 13 July. Although in this period the situation between China and Vietnam quite sensitive, people still purchase Chinese products. In one month, household 1 and household 4 in their shopping list include Chinese goods.

##### Quantitative Data

Descriptive statistics will be shown such as frequency and percentage of every determinant of demographics. There are 354 valid responses from the respondents. Clearly, our demographic factors consist of gender, age, income, marital status and accommodation.

### 4.2. Reliability test

According to George et al. (2003), Cronbach's Alpha must at least 0.6 ( $\alpha \geq 0.6$ ) to be considered as valid. Following to Nunnally and Burnstein (1994), corrected item-total correlation is acceptable for reliability analysis of the research when it  $\geq 0.3$ .

After the analysis, every observed variable has Cronbach alpha above 0.6 which means reliability test is decent for further measurements. Then, all the variable in the column Corrected Item – Total Correlation are greater than 0.3. In summary, all items (CET, CAN, NOS and PDE) are acceptable and sufficient enough for the study.

### 4.3. Exploratory factor analysis (EFA)

The criteria for EFA include: Kaiser-Meyer-Olkin (KMO) value is considered as valid if  $0.5 \leq KMO \leq 1$  (Kaiser, 1974). Then in the Bartlett's test, if the value sig  $< 0.05$ , that mean observed variables are correlated with each other in the overall. Factor Loading are considered to have practical significance when the value  $> 0.5$ .

#### 4.3.1. EFA for Independent Variables

$KMO = 0.770 > 0.5$ . It means that exploratory factor analysis for independent variables is appreciated with research data.

Bartlett test (Sig. =  $0.00 < 0.05$ ). It indicates that variables have the correlation in overall.

There are three dimensions are remained, Eigenvalue values from 2.187 and upwards ( $> 1$ ) so the variation explained by each component.

Initial Eigenvalues (Cumulative %) = 64.944%  $> 50\%$ . This means that these three factors can explain 64.944% data variation in observed variables.

All items have factor loading are higher than 0.5, this mean all of the items have practical meanings (Hair et al. 2008).

As all of the requirements are met, and items of every construct are grouped together, all of the independent variables remain appropriate.

#### 4.3.2. EFA for Dependent Variable

$KMO = 0.570 > 0.5$ . As a result, exploratory factor analysis for dependent variable is accepted.

Bartlett test (Sig. =  $0.000 < 0.05$ ). It indicates that there are correlations in overall.

Study has one dependent factor with Eigenvalues =  $1.963 > 1$

Initial Eigenvalues (Cumulative %) = 65.434%  $> 50\%$ . It means that PDE factor can explained 65.434% data variation of observed variables.

Factor loadings of items  $> 0.5$  (meet the condition) Results of factor analysis show that data use in study is accepted for correlation analysis and regression analysis.

#### 4.4. Correlation & linear aggression analysis

##### 4.4.1. Correlation Analysis

Pearson Correlation coefficient is a measure of the relationship between two variables X and Y developed by Karl Pearson from a related idea introduced by Francis Galton in the 1880s (Pearson, 1895). Following (Trọng & Ngọc, 2008), in Pearson Correlation coefficient test also need to consider Sig. (2-tailed) which is sig check whether the relationship between the two variables is meaningful or not. Sig < 0.05, significant correlation; sig  $\geq$  0.05, correlation was not significant. All three factors show the Sig. value < 0.05 compare with the dependent factor and  $|r| > 0$ . That mean three factor have the relationship with purchase decision factor.

##### 4.4.2. Regression analysis

*Regression equation:*

$$PDE = \beta_0 (\text{Constant}) + \beta_1 \times \text{CET} + \beta_2 \times \text{CAN} + \beta_3 \times \text{NOS}$$

It consists of 3 independent variables and 1 dependent variable. The adjusted R-square equals to 0.292. This statistical value describes that 29.2% dependent variable's variation (PDE) can be explained by 3 independent variables (CET, CAN, NOS). Besides that, Durbin – Watson (d) = 1.547, so this value is in the range from  $1.5 < d < 2.5$ . Therefore, we do not have the autocorrelation (Hair et al., 2009). Sig. (F) = 0.00 < 0.05, it means that the regression model is appropriate. Also, the Sig. (CET) and Sig. (NOS) < 0.05 so these factors have meaning in statistic with reliability is 95%. However, Sig. (CAN) > 0.05 so the factor CAN do not have meaning in statistically. The changing in CAN factor causes no effect on the CAN, so factor CAN is removed. Moreover, following the hypothesis that CET has the negative relationship with PDE but the Standardized Regression Coefficient (Beta) result show that CET don't have the negative effect on PDE.

Therefore, we also remove factor CET. Base on the unstandardized coefficients we have the linear regression equation:

$$PDE = 0.359 + 0.267 * \text{NOS}$$

In this equation, (PDE) is purchase decision and (NOS) is nostalgia. Every increase of 0.267 (NOS) will increase 1 unit of PDE (household purchase decision with Chinese product).

##### 4.4.3 Hypotheses testing

H1: There is a negative relationship between ethnocentrism and purchase decision.	Rejected
H2: There is a negative relationship between animosity and purchase decision.	Rejected
H3: There is a positive relationship between Nostalgia and purchase decision.	Accepted

**Table 4.1: Hypothesis testing**

#### 4.5. Discriminant analysis in demographic variables

##### 4.5.1. Independent T-test

Based on results, Sig = 0.502  $\geq$  0.05 in Levene's Test for Equality of Variances, Equal variances assumed is valid. And it is 0.782 > 0.05, the null hypothesis is accepted. Thus it means there is no significant difference in the mean of purchase decision between male and female.

##### 4.5.2. ANOVA

Age, Monthly Income, Marital Status and accommodation sig values are above 0.05 in Test of Homogeneity of Variances and it shows that the homogeneous covariance condition is satisfied that there is no difference in covariance between the groups, so ANOVA method is appropriate. In ANOVA table, the Sig in Monthly Income, Marital Status and Accommodation is above 0.05, so we can claim that there is no different mean about purchase decision of customers for Monthly Income, Marital Status and Accommodation group. However, in Age factor in INOVA table, because Sig = 0.028 < 0.05, it shows that There is difference in the mean of purchase decision between age group.

In conclusion, the result of ANOVA Analysis shows that purchase decision of household is not influenced by gender, monthly income, marital status and accommodation. However, it will be influenced by age.

## V. FINDINGS & RECOMMENDATIONS

### 5.1. Finding and answer to question objectives

#### 5.1.1. Animosity

Survey	Interview	Bill
-No effect (Regression analysis the sig is 0.567 and standardized beta is 0.026) -Analysis of surveys show that Animosity is not taken into consideration.	-Mildly negative effect (7 of 16 claim to never buy products made in China due to their actions) -Slightly more than half (9 of 16) of the respondents claims that Animosity does not affect them	- 2 household out of 4 bought Chinese product. -A small amount of products bought (<10%) of all households are still Chinese products.

**Table 5.1: Consumer Animosity towards China**

#### 5.1.2. Nostalgia

Survey	Interview	Bill
-Postive effect (Regression analysis the sig is 0.000 and standardized beta is 0.256) -Large portion of people aged 18-25 agree with Nostalgia	-No effect ( 14 people said Nostalgia don't affect their purchase decision) -Majority of respondents does not think Nostalgia affect their behaviour	-N/A -Not sufficient information from bills to draw conclusions.

**Table 5.2: Consumer Nostalgia towards China**

#### 5.1.3. Ethnocentrism

Survey	Interview	Bill
-No negative effect (Regression analysis the sig is 0.000 and standardized beta is 0.431) -Analysis of surveys show that Ethnocentrism towards Vietnam makes people more likely to purchase Chinese products	-Neutral effect (8 people said that they don't feel wrong to their domestic products if they bought a Chinese products) -Exactly half of the respondents claims that it affects what they buy, while the other half claims it does not -Follow-up interview suggests Ethnocentric tendencies is stronger in older people (over 40)	- 2 household out of 4 bought Chinese product. - A small amount of products bought (<10%) of all households are still Chinese products

**Table 5.3: Consumer Ethnocentrism towards China**

### Implications

Some of the current perspective on globalization ("World is Flat" –Thomas Friedman 2005) shows that people are becoming more and more ambivalent about the country of origin characteristics. From our research results, Vietnam, in particular, seems to be in the process of a paradigm shift regarding perspectives, this changes purchase decision making a lot, and some of the research results from earlier studies might not be applied anymore. It is time that a study of sub-cultural groups in various countries is conducted to gain a better understanding and more insights into the nature and magnitude of cultural perspectives on product and country evaluations. Our research objective is to find out the effect of Ethnocentrism, Animosity and Nostalgia in particular on the purchase decision of households

in Vietnam, specifically a case study of Chinese imported products. Through research, we concluded that Ethnocentrism and Animosity are becoming less and less prevalent as a method of determining consumer purchase decisions, while Nostalgia is a factor as useful as previous studies suggest to be, able to stimulate a positive respond from consumers, but not as strongly as the other 2 factors. Besides, we are so grateful to provide market information for everyone – especially many companies in country to improve some business strategies.

### 5.2. Recommendation

#### 5.2.1. For Chinese or China-related companies

As said before, although Animosity and Ethnocentrism do not negatively affect household

purchase decisions, the majority of purchase decisions are made as an individual, which according to our surveys and interview does negatively impact it. Our group recommends that instead of marketing the product as being part of a brand name, the sold products will be marketed under its own name, because less identification of a brand reduces ethnocentrism against it (Batra et al. 2000). Chinese and China-related Company should care about the price and quality of the product if they want to get the attention from the Vietnam user. They should consider about Electronic Goods and Clothes if they want to work in the Vietnam market. Furthermore, should have extensive research about consumers in other more rural parts of Vietnam must be prepared to gauge their reactions towards Chinese products carefully.

### 5.2.2. For Vietnamese Retailer

Knowing how Animosity and Ethnocentrism do not affect purchase decisions as greatly as before is a huge help in selecting which products to import for maximum profits, as well as how to do product displays. Using the advantage of Chinese branded products, being their low price-to-quality ratio, and the decreasing effects of Animosity and Ethnocentrism on the purchase decision, more products with the differing price range, in general, can be sold, enhancing sales and profit.

### 5.2.3. Other recommendation

A little finding we found during interviewing is that older people above the age of 36 (100% of people in this age range) tend to focus and check the country of origin very carefully, however, most people from 18-35 (80% of people in this age range) value availability over anything else, since their lives are always in a hurry. Exploiting this fact might be one way for new products to make its way into Vietnamese people's daily life and cement itself as a Nostalgia product while Animosity and Ethnocentricism are no problems yet, and with the expansion of Convenience Stores over the last few years, it had only become more and more straightforward to make one's products readily available.

### 5.3. Limitations recommendation for further research

First of all, due to the lack of time, human resources, and finance, the method of data collection for all types of research methods employ convenient sampling, making the effectiveness of the chosen samples not as reliable as we would like.

Secondly, the researched location was very limited, leaving more than 61 out of 63 towns and cities that could not be investigated, and while we had indeed picked the two most significant economic hubs in Vietnam and there are still many opinions to be

heard and make research.

Moreover, it is the fact that the research model has adjusted R square of 0.292. It indicates that only 29.2% variability of consumer decision towards Chinese imported product is explained by the model. As a result, there are other uncovered and more influential components might exist so, further researches have to consider those factors together with others elements to apply in the scales.

Finally, with our limitation regarding above the managers and company relate to Chinese products should consider their specific situations as well as objectives and apply appropriate suggestions to practices to get the benefit for their businesses.

### REFERENCES

- Bryman, A. and Bell, E., 2015. Business research methods. Oxford University Press, USA.
- Creswell, J.W., 2012. Educational research. Planning, conducting, and evaluating quantitative and qualitative research.
- Davis, H.L., 1976. Decision making within the household. Journal of consumer research, 2(4), pp.241-260.
- George, D. and Mallery, M., 2003. Using SPSS for Windows step by step: a simple guide and reference.
- Joshi, Rakesh Mohan, (2009) International Business, Oxford University Press, New Delhi and New York.
- Hair, J.F., Celsi, M., Ortinau, D.J. and Bush, R.P., 2008. Essentials of marketing research. New
- Holbrook, M. B., & Schindler, R. M. (1991). Echoes of the dear departed past: Some working progress on nostalgia. Advances in Consumer Research, 18,330 - 333.
- Holbrook, M. B. (1993). Nostalgia and consumption preferences: Some emerging patterns of consumer tastes. Journal of Consumer Research, 20(2), 245-256.
- Holbrook, M. B. (1993). Nostalgia and consumption preferences: Some emerging patterns of consumer tastes. Journal of Consumer Research, 20(2), 245-256.
- Klein, J. G., Ettenson, R. & Morris, M. D. (1998). The animosity model of foreign product purchase: An empirical test in the People's Republic of China. The Journal of Marketing, 2, 89-100.
- Nguyen, T.B., 2011. The trend of Vietnamese household size in recent years. In International Conference on Humanities, Society and Culture. International Proceedings of Economics Development and Research (Vol. 20).



Saunders, M. N., 2009. In: Research Methods for Business Students. s.l.: Pearson; 5 edition.

Sharma, S., Terence, A. S. & Jeongshin, S. (1995). Consumer Ethnocentrism: A Test of Antecedents and Moderators. *Journal of Academy of Marketing Science*, 23(1), 26-37.

Shimp, T. A. & Sharma, S. (1987). Consumer ethnocentrism: Construction and validation of the CETSCALE. *Journal of Marketing Research*, Vol. 24, pp. 280–289.

Yor Hair, J.F., Black, W.C. and Balin, B., 2009. BJ, & Anderson, RE (2010). *Multivariate data analysis*, 7.k, NY: McGraw-Hill/Higher Education.



# **Papers of Technical Sector**



## Call-Center on Mobile for Clinics

**Nguyen The Phuong**  
FPT University  
HCMC, Viet Nam

**Phan Thanh Thuan**  
FPT University  
HCMC, Viet Nam

**Nguyen Cao Duy**  
FPT University  
HCMC, Viet Nam

**Nguyen Luong Tuan Kiet**  
FPT University  
HCMC, Viet Nam

### Abstract

*At the present, the clinic usually uses traditional ways to receive the call, that is hiring a switchboard operator. But, that solution has a few problems such as missed call or receive the wrong information. So, the use of switchboard operator to received call do not high efficiency.*

*Another way to solve this problem for the clinic is Call-Center, the clinic will rent the traditional Call-Center to receive the call from patients. In this method, Call-Center will provide more professional service for the clinic, but the cost is quite expensive and it is hard to exchange appointment information for the clinic.*

*That is the reason why we decided to build an automatically Call-Center system to save time and cost for the clinic. When there is a call from the patient, the system will pick up the call automatically, receive information and schedule appointment for the patient. After that, the system will send SMS about appointment information for the patient. Our system also allows patient book appointment via SMS like the way above. The clinic just accesses the system to view all schedule appointment.*

### Keywords

*Automatically Call-Center, Schedule appointment, Speech To Text, Text To Speech.*

### I. INTRODUCTION

Call-Center on mobile for clinic is the system we build to provide booking appointment services for the patient by hot line phone number. Our approach contains a main problem is booking appointment service by the call.

Booking appointment service by the call is the way we allow patient call to clinic phone number and interactive with the system to make appointment. To do that we need to control a clinic's phone number, that is mean when clinic's phone number have any incoming call, our system will pick up a call automatically, answer to the patient by a voice and also receive information when patient talk.

In the detail, we build booking appointment service with following flow:

- When a patient call to clinic's phone number, we pick up a call automatically.
- Then answer to the patient by hello message and guiding patient how to book appointment.
- Next step is listen patient's information
- Once the patient's information is available, the system will analyze that data and make appointment.
- The last thing is the system will announce appointment's information to patient.

### II. PROBLEM AND SOLUTION PLAN

When we start to identify problems and find the way to resolve them, we found many difficult things. We decide to use smartphone as a switchboard to receive and answer a call. We try on both Android and IOS but as we know that, take the privilege of system phone is really hard things. We try to root Android system and jailbreak IOS to take that privilege but it still not worked correctly. And event after many hours research we find the way to done the first step is auto pick up phone call (only working on Samsung's device). We instantly face another problem, we cannot send voice answer when we are receiving the call. So, we fail in that way.

After that, we change the way of looking for this problem, that is building a system with 02 servers, the first one is the Hotline Server which provides any services of our system, and the second is Clinic Server which controls the clinic phone number. Both communicate with each other using Web API.

Clinic Server listens to some events like incoming SMS signal, incoming call signal, hang up, etc. If any event occurs, Clinic Server will send a request to Hotline Server to handle that event. Our two big issues are sending voice answer to the patient and collecting information when patient talk, these issues will be resolved by Clinic Server as follows:

- Collecting information when patient talk: Clinic Server record a call and save it into a file, then send a recorded file and related information to Hotline Server
- Send voice answer to the patient: Hotline Server translates text to a voice and save this voice into a

file, then send the audio file to Clinic Server. The last thing, Clinic Server just play that audio file to patient

### III. PLAN IMPLEMENTATION

Fortunately, in the process of researching how to implement the system mentioned above, we found a Third-Party Framework that offers several features similar to the Clinic Server we are building, it is Twilio [1]. Finally, we choose Twilio to help us implement our system.

Our system solves the problem by using 03 main algorithms as below

#### 3.1. Schedule appointment

After the system analyzed information received from patient via SMS or the call, we need to estimate a time for appointment. To implement this algorithm, we use information about working hours of the clinic which is configured yet.

The appointment time is calculated based on formula:

$$\text{Estimate\_Time} = \text{Base\_Time} + \text{Examination\_Duration}$$

Detail description:

- Estimate\_Time: The time estimated for new appointment
- Examination\_Duration: The duration for one examination which configured by clinic
- Start\_Working: The start working time which configured by the clinic
- End\_Working: The end working time which configured by the clinic
- Last\_Appointment: The time of last appointment on the day of clinic
- Delay\_Duration: The duration of epsilon time for working hours
- Base\_Time:
  - + If no appointment made on that day, Base\_Time is Start\_Working and set Examination\_Duration = 0
  - + If clinic has any appointment on that day, Base\_Time is the time of Last\_Appointment
  - If Base\_Time is early than current time, Base\_Time is the current time

If estimate time of new appointment is later than (End\_Working + Delay\_Duration), that appointment cannot creating.

#### 3.2. Book appointment by the call

When our system receives the call from patient, who want to book appointment. We must to guide patient how to book appointment and collect information patient was response, bases on that information we make appointment for patient.

The processing model of booking appointment following these steps:

- 1) Guiding the patient book appointment when system receive a call
  - Check a call is valid or not
  - + If the patient's phone number is blocked by the

clinic, our system finishes a call and notify to patient the reason

+ If this is the time clinic does not workings, our system finishes a call and announce the non-working time of clinic to patient

- After condition checking done, the system find and play greeting audio file of clinic which contain hello message and guiding message of clinic

- After play greeting audio file, the system plays beep sound and start recording a call.

2) Analyzing patient's information which input on the call

- When the patient silence in 2s or press any key, our system stops recording and save recorded file.

- Next step, our system gets patient's name from recorded file by the way translate voice to text.

- If that patient already booked appointment on this day, our system will send error message to the patient and finish this algorithm

3) Estimation time for appointment using "Schedule Appointment" algorithm

- Get estimation time for appointment using "Schedule Appointment" algorithm

- If estimation time is valid we continue step 4)

- If estimation time is invalid, our system will send error message to the patient and finish this algorithm

4) The announcement about appointment's information for patient and clinic: Based on estimation time, our system will announce an appointment information to patient and clinic.

Flow chart of this algorithm as Figure 1

#### 3.3. Book appointment by SMS

When our system receives the SMS from patient, who want to book appointment. We must to analyze information on a SMS and try to make appointment base on that information, and then announce the result to patient.

The processing model of booking appointment following these steps:

1) Check appointment booking

- If SMS booking appointment is wrong format, our system will send guiding message to the patient and finish this algorithm

- If the patient's phone number is blocked by the clinic, our system will notify to patient the reason and finish this algorithm

- If this is the time clinic does not workings, our system announce the non-working time of clinic to patient and finish this algorithm

- If the patient already booked appointment on this day, our system will send error message to the patient and finish this algorithm

2) Estimation time for appointment using "Schedule Appointment" algorithm

- Get estimation time for appointment using

“Schedule Appointment” algorithm

- If estimation time is valid we continue step 3
  - If estimation time is invalid, our system will send error message to the patient and finish this algorithm.
- 3) Announcement about appointment’s information for patient and clinic: base on estimation time, our system will announce appointment information to patient and clinic.

Flow chart of this algorithm as Figure 2

#### IV. ANALYSIS

To implement the “Schedule Appointment” algorithm, we need to find the last appointment on the day of the clinic, that’s mean we must to traverses all appointments because our system contains many clinics and each clinic have many appointments. In totally, the complexity of this algorithm is  $O(n)$  with  $n$  is the number of all appointments in our system.

In the testing environment, we use the Hotline Server with the configuration as below:

Hardware	Specification
Internet Connection	Cable 60 Mbps
Operating System	Window Server 2016
CPU	Intel® Xeon ® Processors
Computer Memory	8GB RAM

Execution time for “book appointment by the call” algorithm is approximately 10 seconds with the detail as below:

- Twilio Server sends a request to Hotline Server: ~1s
- Get patient’s name from the recorded file: ~2.5s
- Process and save data: ~0.5s
- Get an audio file from text message: ~5s
- Hotline Server sends response data to Twilio: ~1s

Execution time for “book appointment by SMS” algorithm is approximately 3 seconds with the detail as below:

- Twilio Server sends a request to Hotline Server: ~1s
- Process and save data: ~0.5s
- Hotline Server sends response data to Twilio: ~1s
- Twilio handle response and send SMS to the patient: ~0.5s

#### V. EXPERIMENTAL RESULT AND CONCLUSION

Our system provides automatically Call-Center for the clinic, this is our exertion to help the clinic reduce costs and save the time. However, limit of the time forces us to uses some third-party frameworks and that makes a performance of the system is not good.

#### ACKNOWLEDGMENT

We are want to send a big thank to our advisor, Mr. Kieu Trong Khanh. About his idea and the way he guides us, leads us to overcome difficulties in this project. We learned a lot from these things and we appreciate about all of this. Once again we want to thank him and look forward to working with him.

#### REFERENCES

- [1] Twilio documents “<https://www.twilio.com/docs/>”



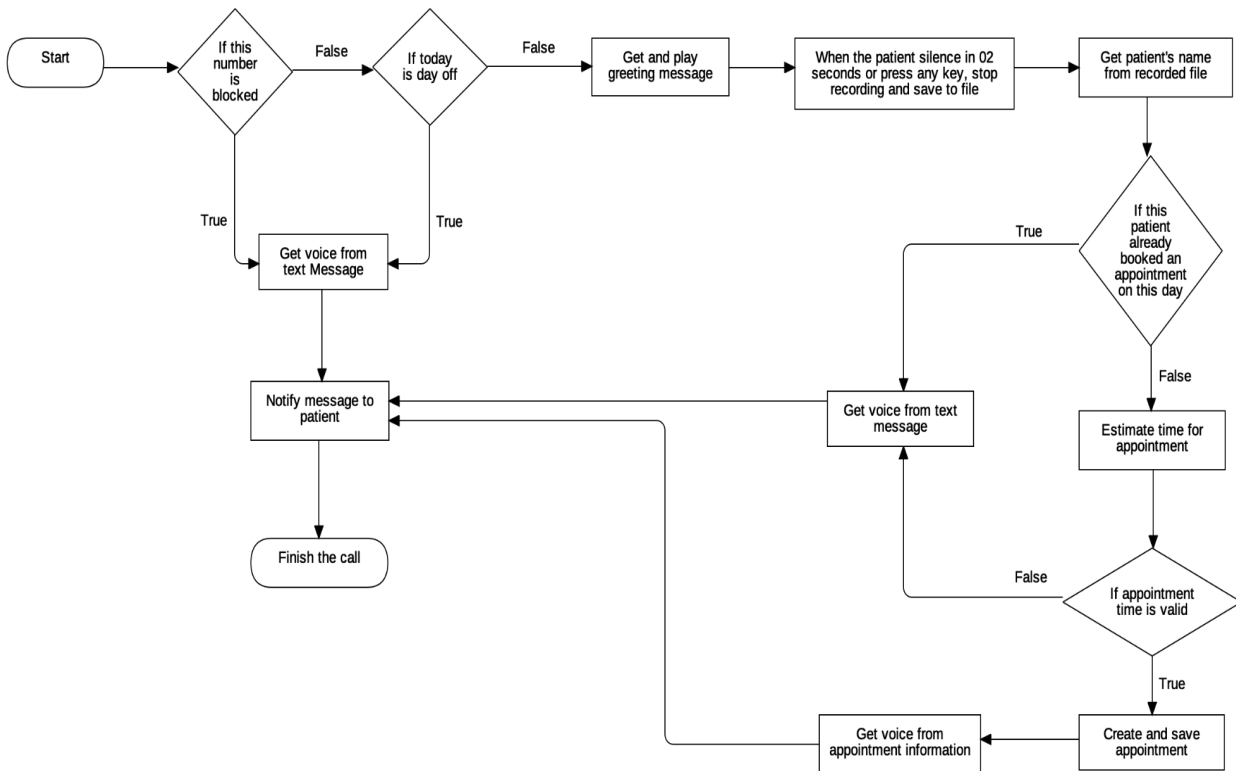

Figure 1: Flow Chart Book Appointment By A Call

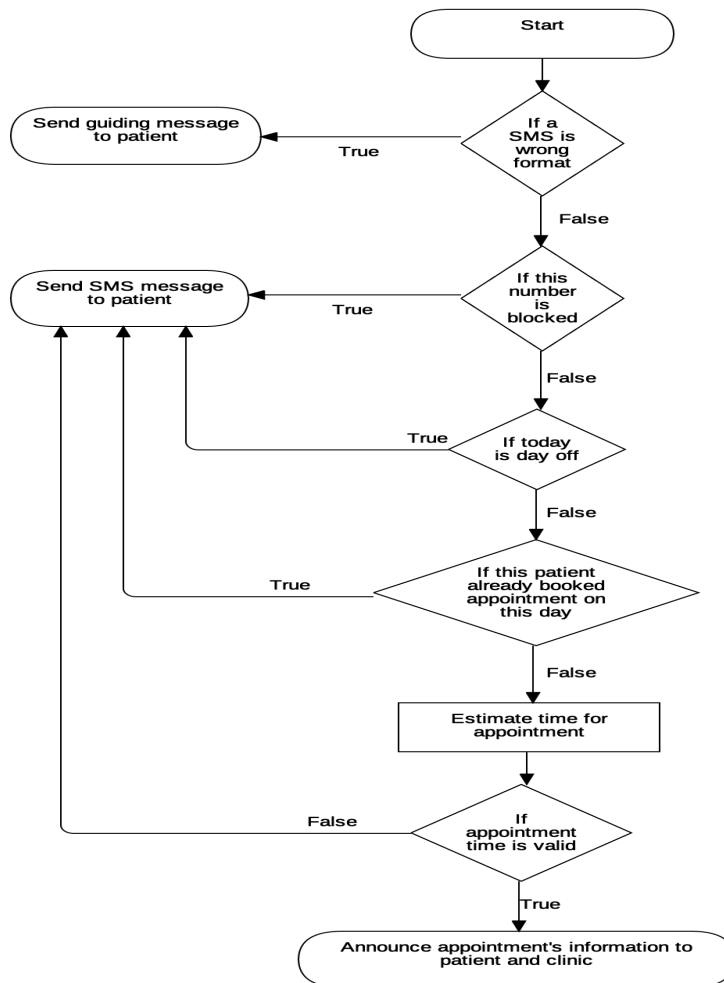

Figure 2: Flow Chart Book Appointment By SMS

# Criminal Face Detection

**Le Hung Son**  
FPT University  
HCMC, Viet Nam

**Vo Hoang Viet**  
FPT University  
HCMC, Viet Nam

**Nguyen Thanh Nha**  
FPT University  
HCMC, Viet Nam

**Nguyen Kien Huy**  
FPT University  
HCMC, Viet Nam

## Abstract

Nowadays technology is growing rapidly, especially in the Image Recognition field. By providing detection of criminals and ex-law offender with high accuracy, Image Recognition technology has become one of the most attractive technologies for development. For banks and customer base companies or private use. Business owners want to protect themselves from criminals and be alarmed if a repeating law offender is present. The ability to know whom you are serving and to alarm and protect your property is invaluable to any business owners

## Keywords

Face Detection, Criminal

## I. INTRODUCTION

Today most of the supermarket, business owner, public place or hospital all have security camera, but the manpower use to watch those security cameras is miniscule. The practice of 1 or 2 security officer keep watch a security system compose of dozen or more camera over a long period of times bring little result and often than not the practice of checking the camera feed will only be done if the crimes has already happened. At a result business owner cannot effectively defense itself against crime.

As a result, we build a system to help public organizations/places (Super Markets, Hospitals...) detect faces of suspects/criminals. The following workflow and features should be implemented:

- The system connects with cameras in a particular place
- The system captures walk by faces and compares with the built-in data
- If the results are likely matched with the built-in data, alert and notification should be send to administrator via Email and Phone
- The administrator should be able to add/remove facing data

## II. PROBLEM AND SOLUTION

When implement the CFD system, we faced several problems:

## 2.1. Facial Detection

At first when implementing the facial detection system we realize that is very difficult to keep track of even one person face in a span of time because of the head movement, which can be described by the egocentric rotation angles, i.e. pitch, roll and yaw, or camera changing point of views could lead to substantial changes in face appearance and/or shape making automated face recognition across pose a difficult task. Not only that but the facial expression change the age in of the face, the diversity of camera lens which lead to different shade and occlusion lead to the same face but with many different elements, we try to solves this by applies different facial detection library but the result is vary. Therefore, we try to implement machine learning to our system. At a basic the system will be fed a lot of criminal face picture for it to find the similarity and if the matching percentage between what it learn and what the camera take is high enough it will send a match. We choose multi-task CNN to improve the accuracy of multi-view face detection.

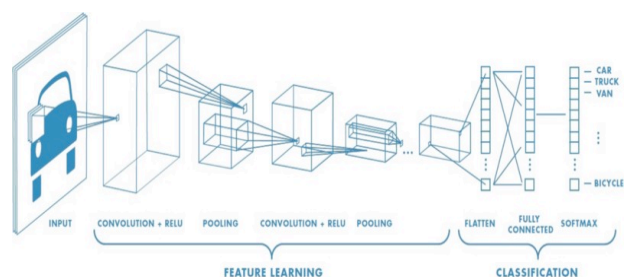

**Figure 1: Neural network with many convolutional layers**

## 2.2. Data training preparation

Convolution network requires large dataset for training. In face recognition field, dataset require about 10,000 – 40,000 images and huge of training time to get a high accuracy output. It's hard to get enough dataset in real situations as our system. When a criminal is arrested, we can capture about 10-50 images for dataset, it's so small for a good dataset.

We come up with two solutions to improve performance by limiting of data: Transfer learning & data augmentation

**2.2.1. Transfer Learning**

We try to train the entire network. But sometime, the new data is similar to the original data. As our research, modern model takes 2-3 weeks to train across multiple GPUs. We just choose the open pretrained-model “Inception-ResNet-1” and work from final check-point to train our own model

**2.2.2. Data Augmentation**

The idea is making alterations to our existing dataset. We divide into two types:

**Type 1: Minor changes**

We can make some minor changes apply to dataset: flip, rotation, scale, cropping.



**Figure 2: From the left, we have the original image, image with scaled inward, image with rotating by 180 degree**

**Type 2: Gaussian Noise**

Convolutional neural network can robustly classify objects even if it’s placed in different orientations. We treat this situation by method: add salt and pepper noise into the image. It is similar to the effect produced by adding Gaussian noise to an image, but may have a lower information distortion level.



**Figure 3: From the left, we have the original image, image with added Gaussian noise, image with added salt and pepper noise**

**2.3. Face Detection**

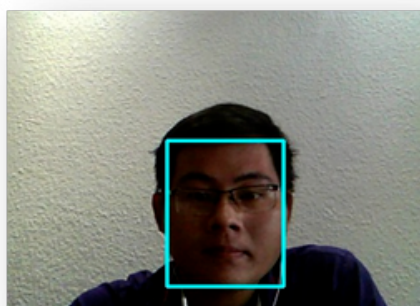

**Figure 4: Bouding-box of face**

The target of the algorithm is to get bounding-box of all faces appear in the input image. The algorithm performs following steps:

**Step 1: Resize image:**

Initially, we resize the input image to different scales to build an image pyramid



**Figure 5: Image pyramid**

**Step 2: Three-stage cascaded:**

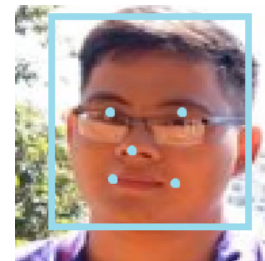

**Figure 6: The five facial landmark points**

Each resized image will be put into three-stage cascaded:

**Stage 1: Proposal Network (P-Net)**

Obtain the candidate facial windows and their bounding box regression vectors

**Stage 2: Re-fined Network (P-Net)**

All candidates are fed to another CNN which rejects a large number of false candidates, performs calibration with bounding box regression

**Stage 3: Output Network (P-Net)**

Similar to the second stage, but in this stage we aim to identify face regions with more supervision.

The network will output five facial landmarks’s position: left eye, right eye, nose, left mouth corner, and right mouth corner.

**• Training Model**

With CNN detectors need to train:

1. Face / non face classification: vector classification

$$(x \in R^2)$$

2. Bouding box regression: representative vector

$$(x \in R^4)$$

3. Facial lanmark localization: vector facial features

$$(x \in R^{10})$$

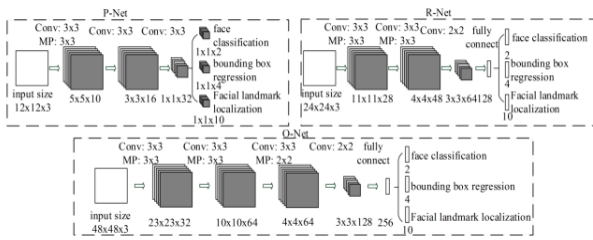

Figure 7: The architectures of P-Net, R-Net, and O-Net

2.4. Face Recognition

After detection, cropped face will be recognize to identify the crime it’s belong to.

• Training model:

We have to train crime’s dataset to a model. Our traning model will run in 4 steps:

Step 1: Load pretrained-model

As a part of transfer learning we mentioned above, we use the pretrained-model and load it first.

Step 2: Load the face dataset

Each crime will have own data directory contains face-dataset. This will be full data, include generated images from augmentation process.

Step 3: Train the last layout

We need to train the last layout of network as a transfer learning idea. The Support Vector Machine (SVM) algorithm is used to categorize our face dataset in this step.

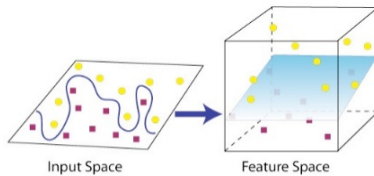

Figure 8: Face categorizes

Step 4: Output new model and terminate.

• Predict Probability

After get the model, we load the model into tensorflow network, and call the prediction, network will output the prediction match (matching density) with rime, example:

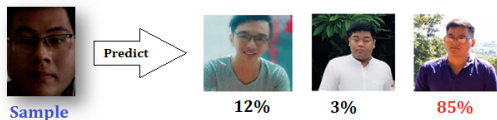

Figure 9: The matching density of sample face with each dataset

Threshold value we set when the face is considered as a crime is . That means the crime is detected if matching density

III. PLAN IMPLEMENTATION

We choose three frameworks for implement the system, following are their advantages:

• Django Rest Framework

We chose Django because is make it easier to implement API service making the development of both out website and Phone application much easier.

• OpenCV 3.0

OpenCV is a library of programming functions primarily aimed at computer vision time

• Tensorflow

An open source software library for high performance numerical computation support in training and load model.

IV. EXPERIMENT RESULT AND CONCLUSION

• Experiment:

The main core of our system is face recognition. So all of our report is experiment of face recognition.

Srenario: we create dataset with 4 difference peoples [Son, Huy, Nha, Viet] and input 10 sample faces of one person [Son] and takes note the change of matching density. The matching density is average number of 10 sample faces.

Exp. 1: Change dataset size

Input image size (image)	Original dataset	After minor changes data set	After Gaussian Noise
5	50%	53%	61%
10	60%	65%	72%
50	75%	78%	90%

Table 1: Experiment with data size

Exp. 2: Change brightness or masked face:

Conditional (standard with 50 images)	Original dataset	After minor changes data set	After Gaussian Noise
Face masked	62%	63%	65%
Normal light	75%	78%	90%
Dark light	72%	74%	78%

Table 2: Experiment with conditional

Exp. 3: Threshold

This table contains recommend threshold for good detection:

Bounding box type	Threshold (t)
Negatives	$t \leq 0.3$
Part of face	$0.3 < t \leq 0.65$
Truth face	$0.65 < t$

Table 3: Threshold for bounding-box

**• Conclusion:**

After experimenting many time, we conclude that is suitable and worth for building a facial detection security system

**Strengths:**

- Flexible for development, many customizations can be done.
- Machine learning system so the more we operate the higher the accuracy.

**Weakness:**

- Development cost is high.
- Need a lot data to make the system accurate.

**ACKNOWLEDGMENT**

This paper owes massive thanks to Mr. Nguyen Huy Hung at FPT University. He was always support us whenever we ran into troubles or had questions about our project. He consistently allowed this project to be our own work but steered us in the right direction whenever he thought we needed it.

**REFERENCE**

- [1]. Christian Szegedy, Sergey Ioffe, Vincent Vanhoucke, and Alex Alemi, "Inception-v4, Inception-ResNet and the Impact of Residual Connections on Learning", pages 4-7, 2016
- [2]. Stanford CS class CS231n. "Convolutional Neural Networks: Architectures, Convolution/ Pooling Layers": <http://cs231n.github.io/convolutional-networks/>
- [3]. Stanford CS class CS231n, "Transfer Learning and Fine-tuning Convolutional Neural Networks": <http://cs231n.github.io/transfer-learning/>
- [4]. Prasad Pai, "Data Augmentation Techniques in CNN using Tensorflow": <https://medium.com/ymedialabs-innovation/data-augmentation-techniques-in-cnn-using-tensorflow-371ae43d5be9>
- [5]. VGG - Visual Geometry Group Home Page - University of Oxford: <http://www.robots.ox.ac.uk/~vgg/>
- [6]. FaceScrub - vision & interaction groupe: <http://vintage.winklerbros.net/facescrub.html>
- [7]. Vojtech Pavlovsky, "Introduction To Convolutional Neural Networks": <http://www.vaetas.cz/posts/intro-convolutional-neural-networks/>
- [8]. Arden Dertat, "Applied Deep Learning - Part 1: Artificial Neural Networks": <https://towardsdatascience.com/applied-deep-learning-part-1-artificial-neural-networks-d7834f67a4f6>



# Vietnamese Keyword Extraction Using Deep Learning Approach

**Nguyen Toan Nguyen**

FPT University  
HCMC, Viet Nam

**Hoang Manh Cuong**

FPT University  
HCMC, Viet Nam

**Ha Huy Hoang**

FPT University  
HCMC, Viet Nam

**Dam Tien Nam**

FPT University  
HCMC, Viet Nam

## **Abstract**

*Keywords provide a short way of reflecting a main idea of the document, giving the reader easier to clear. Because manually extracting keyword is a time-consuming process, it requires much effort; the automatic approaches have been developed. This paper has proposed a solution for the automatic keyword extraction in Vietnamese language using deep learning approach. There are also other tasks for how can we extract candidate Vietnamese keyword and preprocessing Vietnamese text which isn't simple. In this paper, we used the Deep Learning approach to archive our goals. The proposed model shows enhanced precision and f1-score extraction values over another approach.*

## **Keywords**

*Automatic keyword extraction, Classification, Natural language processing, Vietnamese, Recurrent neural network, Bidirectional - LSTM*

## **I. INTRODUCTION**

Nowadays, extracting keywords from documents is very important. With a huge amount of information booming and exponentially increasing on the Internet, it is impossible for a human to perform this task. Identifying keywords from the documents has helped to solve many practical problems such as: Searching for information, summarizing text, mining text, browsing website,... Many people need to synthesize and summarize the information to facilitate the synthesis of such information for after. The automatic keyword extraction approach plays an important role in many core natural language processing tasks.

In particular, keywords allow people to search faster, easier and more effective. Analyzing keywords, searchers can identify the important information in a large dataset quickly.

Investigating on the area, we found that automatic keyword extraction on all domains and topics may take much time just for data entry and training. To give the best result, we only focus on the topic of health care.

The keyword mining is quite popular, demonstrates Natural Language Processing (NLP) and Information Retrieval (IR) [10], however in Vietnam, this is quite new and uncommon. According to our research, the method we use in this document is the latest research methodology in Vietnam.

In this paper, we have presented a keywords extraction system operates in two steps: (1) extracting a list of words/phrases that serve as candidate keywords using grammar pattern based on the heuristic of the noun phrase and determining which of these candidate keywords are correct keywords using supervised or unsupervised approaches.

Keyword Extraction can be called as a binary classification problem [1]. In the exploration of artificial intelligence, there are many methods based on the machine learning techniques such as Naïve Bayes, Decision tree, genetic algorithm [2] [3,4] etc. has achieved many positive results. Especially in recent years, Deep Learning showed a great effect on the task of natural language processing [9]; the more research applied Deep Learning algorithms such as CNN, RNN, LSTM,... to extract the keyword, thereby achieving outstanding results and they are used in real life.

In this paper, we present a keyword extraction method which is trained to output the probability estimate of a class: positive (keyword), negative (not a keyword). We also used different thresholds, which is to identify a keyword or not, by our F1-score of the model. If the output's score of candidate keyword is greater than the threshold, it is the keyword and otherwise. To overcome this problem, we think that the extraction keyword is preferred to be a ranking problem than a classification problem [5,6].

The rest of this paper is organized as follow. Section II presents related work. In section III, the proposed keyword extraction has been discussed. Section IV presents the experiment. Moreover, the last V present the conclusion.

## II. RELATED WORK:

Various approaches to keyphrase extraction have been explored in the past, which can be divided into unsupervised methods and supervised methods.

Unsupervised methods for keyword extraction can be categorized into ranking and clustering candidate keywords to a scoring function.

In supervised methods, it focuses on two issues: task reformulation and feature design. In task reformulation, supervised approaches were considered as a binary classification problem [1]. Approaches using different learning algorithms such as Naïve Bayes [2], Decision Tree [3], ... with a determined keyword to train a classifier which predicts whether a noun phrase is a keyword or not. Later, Jiang et al. [6] proposed a ranking approach to the keyphrase extraction. In feature designing for this task, we used within-collection features such as Statistical features (tf\*idf, frequency), Structural features (position in the document), Syntactic features (PoS tag sequence). We also used other features that will be described in section IV.

Both types of approaches can be viewed and evaluated as a ranking problem. In section IV, we described the candidate keyword extraction using PoS tag with chunk and the features and datasets used.

## III. PROPOSED MODEL

The proposed key-phrase extraction method consists of three primary components: document collection and preprocessing, candidate phrase identification and key-phrase extraction using deep learning approach.

### 3.1. Document collection and preprocessing

The preparation of raw data is very difficult when dealing with the problem related to “Natural Language Processing” especially for Vietnamese.

In this process, data will be collected from Vietnamese newspapers using selenium, and we extract a keyword from every newspaper. The output of this process is a corpus with keywords for each newspaper.

Collected data is about the healthy topic and collect from 4 websites (files) with total files is 524 as shown in Table 1.

Name	Zing	ThanhNien	Suckhoe doisong	Dantri
Number	100	174	100	150

**Table 1: The amount of collected data**

With raw data, we have handle punctuation and tokenize data to have standard data sets.

Vietnamese sentence before tokenize:

“Đại học FPT thành phố Hồ Chí Minh.”

Vietnamese sentence before tokenize:

“Đại\_học FPT thành\_phố Hồ\_Chí\_Minh”

Before training, we divide the collection into three parts: training, validate and test set to avoid overestimating the performance of learned combinations. The data is shown in Table 2.

Data type	Size	Number of documents
Test	10%	52
Training	80%	420
Validate	10%	52

**Table 2: Overview of the test, training and validate set used in our experiments**

### 3.2. Candidate keyword identification

As mentioned in the start of this section, a set of noun phrases and words from a document text is typically extracted as candidate keywords using heuristic rule. To select candidate noun phrases for a given document, we take the full-text content of the document, preprocessed as described above and apply our PoS Pattern (Part of Speech pattern):

(<N.\*>+ <A>\* <E>)? <N.\*>+ <A>\*

<N.\*>+: One or more of any type nouns

<A>\*: Any number of adjectives

<E>: One or zero of preposition

Therefore, this pattern meaning is a noun phrase, which can be combined with two other noun phrases with a preposition word in between.

Using the above grammar and chunking, we have created a result tree, from which we can extract a noun phrase.

For example:

“Nguyễn là một sinh viên giỏi của trường đại học”

Calling a noun phrase we need is candidate keyword (CK). The result is “Nguyễn” and “sinh\_viên giỏi của trường đại\_học” with Np and N-A-E-N-N

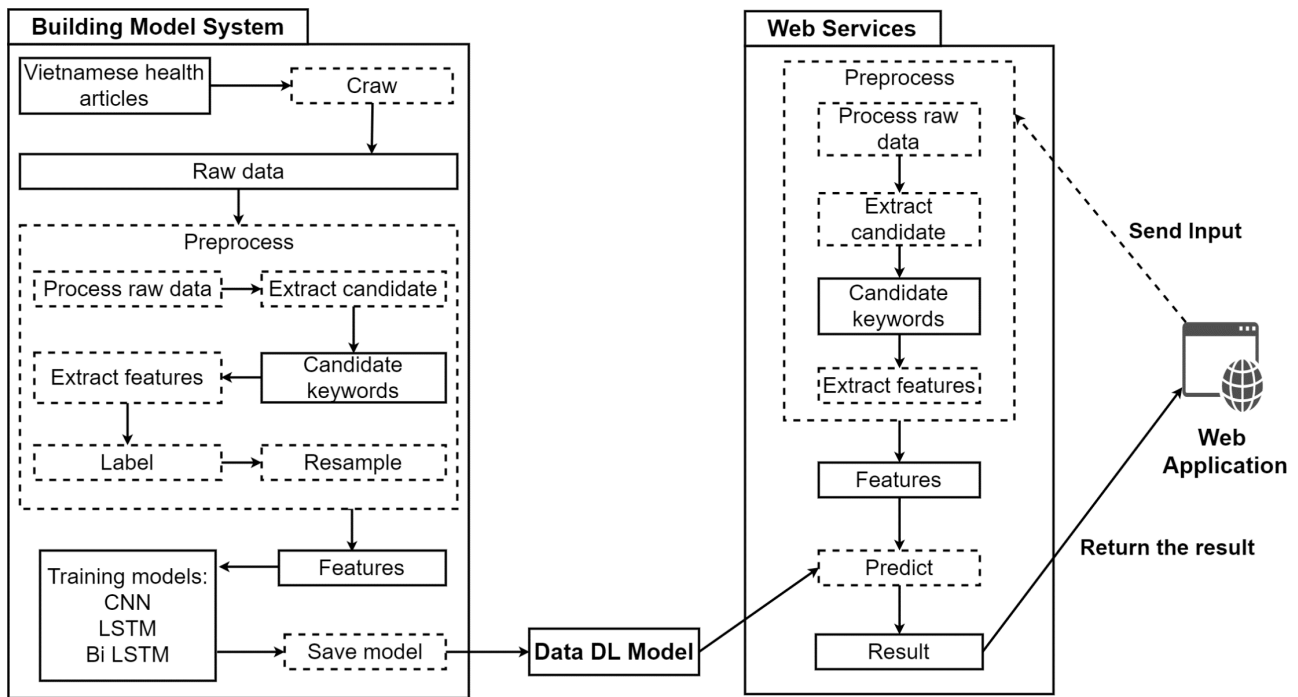

Figure 1: The proposed model overview

Sometimes, NP-chunking gets the noun phrase like “anh ấy”, we call this noun phrase is stop-word and remove it out of list noun phrase. In the experimental process, we found that a noun phrase consisting of 6 or more words are rarely in our corpus. So we filter out all noun phrase that contains more than 6 words in the extracting process.

### 3.3. Extracting features

Our team extract features for candidate keywords from five concepts:

- Word Embedding with Pre-trained model
- Named-Entity Recognition
- Frequency-based
- Position
- Phrase Length and Word Length

#### Word Embedding

Every word has reflected the structure of the word regarding the semantical/morphological/ context / hierarchical / etc. information. The idea of Word Embedding is to capture with them as much as possible and convert it to vectors. We applied Word Embedding to represent a keyword – can be combined by 2 or more words – as a vector by plus vectors to each word in the dictionary we build.

Example:

Vec “Bệnh viện Trung Ương” = Vec”Bệnh viện”+ Vec”Trung Ương”

Vec “Đại học FPT thành phố Hồ Chí Minh” = Vec “Đại học” + Vec “FPT”

Tokenized data and pretrained word2vec (streetcodevn.com) create a dictionary by word2vector model. For words in our corpus is not in the pretrained word2vec, we re-train word2vec

again with our corpus and pretrained word2vec using Gensim Word2vec. We used CBOW [11] and window slide = 5 parameters in Word2Vec for re-trained word2vec.

After re-train, we have the re-trained word2vec for our corpus. Each word is a vector with 300 dimensions.

#### Named-entity recognition

In the research time, we realized that a noun phrase such as “Tp. Hồ Chí Minh”, “Đại học FPT”, “Bệnh viện Từ Dũ” can be a keyword. A noun phrase containing a named-entity that is considered a keyword is higher than others.

Number of words in Noun Phrase: nNP

Number of named-entity words in Noun Phrase: nNER

We combine both single value and the following formula to have a single feature value (F<sub>ner</sub>):

$$F_{ner} = \frac{nNER}{nNP}$$

For example: Consider the keyword “Đại học FPT thành phố Hồ Chí Minh”.

Words: “Đại học”, “FPT”, “thành phố”, “Hồ Chí Minh”

nNP = 4, nNER = 2 (“FPT”, “Hồ Chí Minh”)

F<sub>ner</sub> = nNER/nNP = 2/4 = 0.5

#### Frequency-based

If a noun phrase is occurring more frequently in a document, the phrase is assumed to more important in the document.

Number of times a noun phrase occurs independently in a document: Phrase Frequency (PF).

Number of times a noun phrase appears in full as a part of other noun phrases: Phrase Link Count (PLC) Two features, PF and PLC, are combined to have a single feature value using the following measure:

$$F_{freq} = \sqrt{\frac{1}{2} * PF * PF + PLC}$$

In the above formula, the frequency of a noun phrase (PF) is squared only to give it more important than the phrase link count (PLC). The value 1/2 has been used to moderate the value. We explain below about this formula with an example:

Assume that we have three keywords and PF and PLC for two keywords:

K1 = “sữa mẹ tốt cho trẻ em”, K2 = “sữa mẹ”, K3 = “sữa”

	PF	PLC	PF+PLC
K2	10	5	15
K3	1	14	15

So, for these two cases, the simple addition of PF and PLC do not make any difference in assigning weights to the noun phrases although the independent occurrence of noun phrase K2 is more than that of the noun phrase K3. However, the independent existence of a phrase should get higher importance while deciding whether a noun phrase is keyword worthy or not.

For another more general case about PF and PLC with the same K2 and K3:

	PF	PLC	PF+PLC
K2	14	1	15
K3	1	19	20

In this situation, the simple addition of PF and PLC will favour the K3 “sữa”, but our formula will give a higher score to the K2 “sữa mẹ” because it occurs more independently than the K3 “sữa”.

Inverse document frequency (IDF) is a useful measure to determine the commonness of a term in a corpus.

$$IDF = \log \frac{N}{df}$$

N = total number of documents in a corpus.

df (document frequency) = the number of documents in which a term occurs.

A term with a lower df value means the term is less frequent in the corpus and hence IDF value becomes higher. So, if IDF value of a term is higher, the term is relatively rare in the corpus. In this way, IDF value is a measure for determining the rarity of a term in a corpus.

In TFIDF, where TF indicates the frequency of a term in a document, TF\*IDF measure favours a relatively rare term which is more frequent in a document. We combine F\_freq and IDF in the following formula to have a variant of the Edmundsonian thematic feature:

$$F_{thematic} = F_{freq} * IDF$$

The value of this feature is normalized by dividing the value by the maximum the f\_thematic score in a collection of F\_thematic scores obtained by the phrases corresponding to a document. [5]

#### Position

If a noun phrase occurs in the title or abstract of a document, it should be given more score. So, we consider the position of the first occurrence of a noun phrase in a document as a feature. Unlike the previous approach [5] that assume the position of a noun phrase occurred first in the sentence I in the document and computed as a feature, in our work, we assume the position of a noun phrase occurred first in the document as I and computed using the following formula from the previous approach.

$$F_{pos} = \frac{1}{\sqrt{i}}$$

For example, assume that we have the sentence “Cúm A/H1N1 trở lại tại thành phố Hồ Chí Minh.” and the keyword “Cúm A/H1N1”:

i of “Cúm A/H1N1” = 1:

$$F_{pos} = \frac{1}{\sqrt{i}} = \frac{1}{\sqrt{1}} = 1$$

By this feature, we are easy to predict a keyword in the title of a document where F\_pos is near to 1 and in summary of a document where F\_pos is near to 0

#### Phrase Length and Word Length

These two features can be considered as the structural features of a noun phrase. Noun phrase length becomes an important feature in the keyword extraction task because the length of the noun phrase usually varies from 1 word to 5 words. We find that noun phrase consisting of 6 or more words are relatively rare in our corpus.

Length of the words in a noun phrase can be considered as a feature. According to Zipf’s Law [12,13], shorter words occur more frequently than the larger ones. For example, articles occur more frequently in the text. So, the word length can be an indication for the rarity of a word. In the previous approach [5] that considered a length of the longest word in noun phrase as a feature, we realized that a maximum length of single words in Vietnamese is 7 and 80% words in Vietnamese is a compound



word, that is not the same as English. We decided to choose the length of characters in the noun phrase as a feature.

- Length of a noun phrase: PL
- Length of characters in the noun phrase: WL

We combine both single value and the following formula to create a feature [5].

$$F_{PL*WL} = \sqrt{\log(1 + PL) * \log(1 + WL)}$$

For example, assume that we have the keyword “Đại học FPT thành phố Hồ Chí Minh”:

Keyword after tokenize: “Đại\_học FPT thành\_phố Hồ\_Chí\_Minh”

PL = 4, WL = 33

$$\begin{aligned} F_{PL*WL} &= \sqrt{\log(1 + PL) * \log(1 + WL)} \\ &= \sqrt{\log(1 + 4) * \log(1 + 33)} \approx 2.23 \end{aligned}$$

The value of this feature is normalized by dividing the value by the maximum value of the feature in the collection of phrases corresponding to a document.

### 3.4. Labelling and Resampling

Keywords in raw data and candidate keywords will be labeled by comparing each other. 0 is not a keyword, 1 is a keyword. After labelling, our ‘class’ label is an imbalance class, the ratio of points between 2 class 0 and 1 is 9:1. Our deep learning model will predict exactly all of the features have a majority class label and its accuracy will be very high. We want that our model can predict the minority class label good as well which means we want a ratio of False Negative is low.

There are four ways of addressing class imbalance problems like these:

- Synthesis of new minority class instances
- Over-sampling of minority class
- Under-sampling of majority class
- Tweak the cost function to make misclassification of minority instances more important than misclassification of majority instances

For the case of our group’s data, the difference between the keyword and non-keyword terms is huge. That is the main reason for the imbalance problems. We decided to use an over-sampling approach SMOTE [14]. SMOTE is one common method. For each point in the set, find the point k in the minority closest to it and then use the weighted sum of these points to create new data points.

### 3.5. Keyword extraction using deep learning methods

After preparation of the training dataset, a Deep Learning model is trained on the training set to classify the noun phrase as one of two categories: “Positive” or “Negative”. Positive category indicates that a noun phrase is a keyword and the

negative category indicates that it is not a keyword. In this paper, we apply 3 Deep Learning model: LSTM [8], Bi-LSTM [7], CNN [4]. Input is a feature’s vector of candidate keyword. Under the influence of the sigmoid activation, the output will be in range 0 to 1. The output determine which candidate keyword is a keyword (1) or not (0) For our training models, we use Keras (<https://keras.io/>) deep learning tools which provide many useful layer and parameter. The model of the Keras suite has been trained with the following values of its parameters:

Number of layers: 3 (one input layer, one hidden layer and one output layer).

#### In LSTM and Bi-LSTM

Number of hidden nodes: 128

#### In CNN

Number of convolution layer nodes: 128

Kernel size:5

Max pool: 4D

Drop out: 0.4

Activate function in the output layer: Sigmoid

Training iteration (epochs): 1000

Batch size: 500

Optimization function: Adam

Loss function: Binary cross entropy

Keras also uses backpropagation algorithm for training the network model.

## IV. EXPERIMENT

In the experiment process, we analyse our training and validating dataset and test dataset as shown in Table 3.

We evaluate our proposed model base on Precision, Recall and F1-score with test dataset. To evaluate our proposed model, we train another model and compare the result of our model with another model. The result shows that our proposed model got better than all another model both on F1-score and Precision as shown in Table 4.

Newspaper	Training and validating	Testing
Document	472	52
Number of most candidate keywords	229	173
Number of less candidate keywords	13	25
Most words in document	1133	1473
Fewer words in document	135	65
Average number of words	419.9	444.8

**Table 3: Data analysis**



Model	Precision	Recall	F1-Score
CNN	0.1814	0.0714	0.0835
LSTM	0.2336	0.8588	0.3404
Bi-LSTM	0.2732	0.3351	0.2632
CNN with Pre-trained word2vec	0.2914	0.6618	0.3766
LSTM with Pre-trained word2vec	0.3113	0.6414	0.3879
Bi-LSTM with Pre-trained word2vec	0.3466	0.6014	0.4051

**Table 4: Comparison of deep learning models**

When classifying a keyword, the output is between 0 and 1. In normal, the threshold of classification is 0.5. It means when a score of a new candidate keyword is higher than 0.5, it is a keyword. Choosing threshold is a part of the decision component. In our problem, we try five thresholds in the range [0.3 – 0.7] to decide which is a keyword with our test data. We used F1 Score to evaluate our best model's Threshold as shown in Table 5. Our best model is Bi-LSTM with pretrained Word2Vec.

Threshold	F1-Score
0.3	0.4327
0.4	0.4296
0.5	0.4324
0.6	0.4201
0.7	0.3968

**Table 5: Comparison of Thresholds**

We also build a web application for help foreigner studying Vietnamese. The web application applies our proposed model in the quiz document. The number of success answer with document have highlight keyword is greater than the other.

## V. CONCLUSION

The automatic keyword extraction from Vietnamese texts is important for many applications including mobile browsing website, search engines, sale words, et. It also is the subtask of other natural language processing such as text summarization, text categorization, document clustering.

This paper has presented a solution for automatic extract keyword in Vietnamese texts. In our experiments, testing with topic about health care is very good, the point-wise approach shows the acceptable result. We believe that larger data about other topic may show the better predict result. Our proposed model also show that Bi-LSTM give the

best result for our corpus and solution.

The negative consequence of this approach is required a large data, which take a time-consuming process for human. We have to crawl it from some websites and extract keyword for each newspaper manually. Although our corpus has been edited by the language expert, it's still unsure. We will improve our corpus in the future. Moreover, this task request other problem in NLP such as text tokenize, pos tagging and name entity recognition have a better accuracy to do. That tasks in Vietnamese text is also new and quite.

## REFERENCES

- [1] J. Wang, H. Peng, J.-S. Hu, Automatic Keyphrases Extraction from Document Using Neural Network., ICMLC 2005, 633-641.
- [2] E. Frank, G. W. Paynter, I. H. Witten, C. Gutwin and C. G. Nevill-Manning(1999) Domain-specific keyphrase extraction. pp. 668–673.
- [3] P. Turney(1999) Learning to extract keyphrases from text. National Research Council Canada, Institute for Information Technology, Technical Report ERB-1057.
- [4] LeCun et al.(1999), "Object Recognition with Gradient Based Learning"
- [5] A New Approach to Keyphrase Extraction Using Neural Networks from Kamal Sarkar, Mita Nasipuri and Suranjan Ghose Computer Science and Engineering Department, Jadavpur University, Kolkata-700 032, India
- [6] X. Jiang, Y. Hu and H. Li(2009) A ranking approach to keyphrase extraction. pp. 756–757
- [7] Schuster M., Paliwal K.K. Bidirectional recurrent neural networks.
- [8] Hochreiter, Sepp; Schmidhuber, Jürgen (1997-11-01). "Long Short-Term Memory". *Neural Computation*. 9 (8): 1735–1780.
- [9] Tom Young, Devamanyu Hazarika, Soujanya Poria, Erik Cambria (2018) Recent Trends in Deep Learning Based Natural Language Processing
- [10] C. D. Manning, P. Raghavan, H. Schütze " et al. , Introduction to information retrieval. Cambridge university press Cambridge, 2008, vol. 1, no. 1.
- [11] T. Mikolov, K. Chen, G. Corrado, and J. Dean, "Efficient estimation of word representations in vector space," arXiv preprint arXiv:1301.3781 , 2013.
- [12] Zipf George K. 1935. The psychology of language. Houghton-Mifflin.

[13] Zipf George K. 1949. Human behavior and the principle of least effort. Addison-Wesley.

[14] Chawla, N.; Bowyer, K.; Hall, L.; and Kegelmeyer, P. 2002. Smote: Synthetic minority over-sampling technique. Journal of Artificial Intelligence 16:321–357.

# Design and Implement Street Lighting Control System Using Power Line Communication

**Vo Truong Thinh**

FPT University  
HCMC, Viet Nam

**Truong Chieu Khang**

FPT University  
HCMC, Viet Nam

**Tran Tat Dat**

FPT University  
HCMC, Viet Nam

## Abstract

*Powerline Communication is a new communication technology that enables sending data over existing power cables. This means that, with just power cables running to an electronic device, one can both power it up and at the same time control/retrieve data from it in a half-duplex manner. In many developed countries, PLC is widely applied in street lighting, industrial, machine-to-machine and transport. However, some developing countries have a little knowledge in PLC, therefore, it is not able to considered replacing other legacy communication technologies in those countries in spite of its advantages. So, we decided to make a research of PLC technology and apply it in the street lighting control system in order to show how it works and demonstrate its benefits in real situations.*

## Keywords

*Powerline communication, STEVAL-IHP005V1 kit, ST7540, CSMA/CA, FSK modulation, transmission mode, receiving mode, transmission frame structure*

## I. INTRODUCTION

There are many communication protocols such as Bluetooth, Zigbee, LoRa, Ethernet or RS485 which are considered to be used for constructing a new street lighting control system. However, all of them cannot solve the problems of installation cost and high demands of security. Otherwise, power line communication is the best solution for this situation thanks to its advantages. Firstly, it limits access to the system from outside. Secondly, PLC uses existing power line for communication within a local network; therefore, it helps to reduce installation and maintenance cost.

Overall, our system includes a web server, which user can control street lighting groups via wireless communication by using a GSM/GPRS network. About hardware, we use a concentrator called gateway and other nodes. The gateway, where receive control signals from the web server, also communicate with other nodes in the network to control the lamps.

## II. PROBLEM AND SOLUTION

### 2.1. Problem definition

Many communication protocols such as LoRa, Bluetooth, Zigbee, Ethernet or RS485 which are considered to be used for developing a new street lighting system. Some of them can solve those problems above. However, all of these protocols are not the best ways in this situation. For example, using wireless communication, it is easy for crackers to attack the system from outside and the transmission speeds are quite slow. Otherwise, using some wire communication protocols like Ethernet or RS485, there are many disadvantages of installation cost and security too.

### 2.2. Proposed solution

There are a lot of benefits of using PLC that can solve all above problems of other communication protocols:

- Devices using PLC can interact with each other directly.
- Using many techniques to ensure data integrity in transmission such as FHSS, CSMA/CA, etc.
- Easy to install and extend.
- High speed data transmission.
- Use existing power grid for communication, so, reduce installation and maintenance costs.
- Closed network can limit access and attack from outside intruders.

In general, our system includes a webserver which has a friendly UI allowing users to control the street lights easily. It can communicate with lighting groups via a GSM/GPRS network by using TCP/IP protocol. The main part of the system is PLM modules. The modules are distributed in the lampposts and one of them is used as a gateway while others are nodes. This model is designed to be a master-slave structure, where the gateway is considered as a master and each node is the slave.

## III. IMPLEMENTATION

### 3.1. Basic concept

The block diagram above illustrates a basic concept of the Street Lighting Control System in which users can communicate with the system via a web application. All control signals have been sent to the

gateway by TCP/IP protocol. There are two main components of the gateway: a GSM/GPRS module which is connected to the Internet or a local network to communicate with the webserver; and a PLM module which receives and processes control signals from the webserver, then broadcasting them to appreciate nodes through powerline. There are also a PLM module installed in each node to communicate with the gateway. All information of nodes and the gateway has been sent back to the webserver periodically and has been stored in a database.

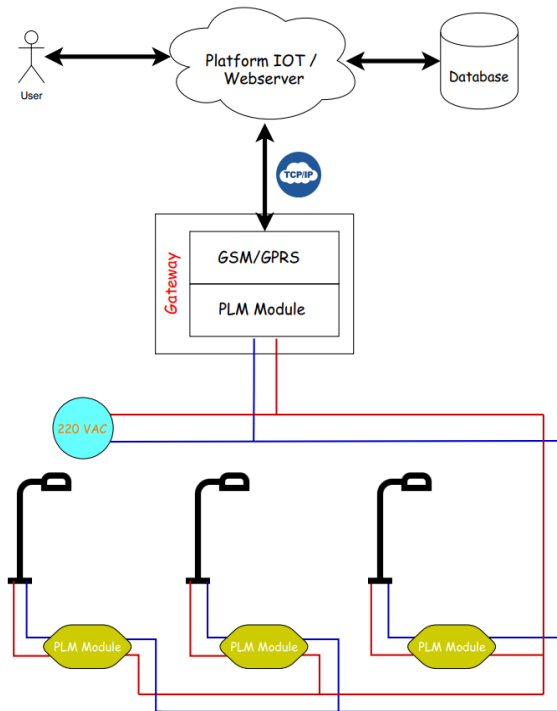

**Figure 1: Street lighting control system – block diagram**

**3.2. PLM module: STEVAL-IHP005V1**

In this project, we use the PLM module of the ST Microelectronics called STEVAL-IHP005V1. It is a high integrated PLM module which can adapt all requirements of a complicated PLC

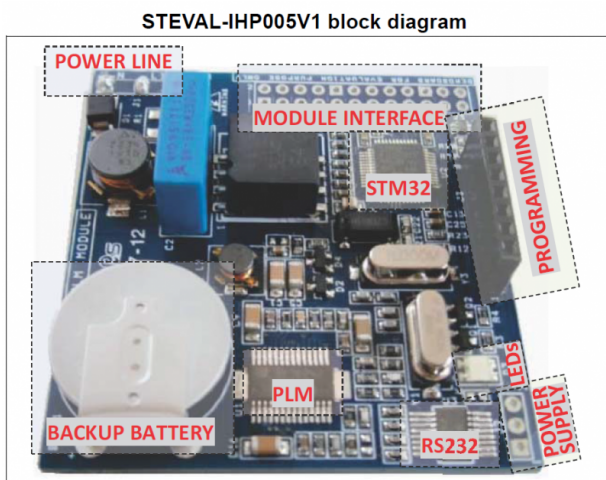

**Figure 2. STEVAL-IHP005V1 – block diagram**

The PLM module is designed with a firmware structure and supported by several libraries that helps developers to modify its features easily.

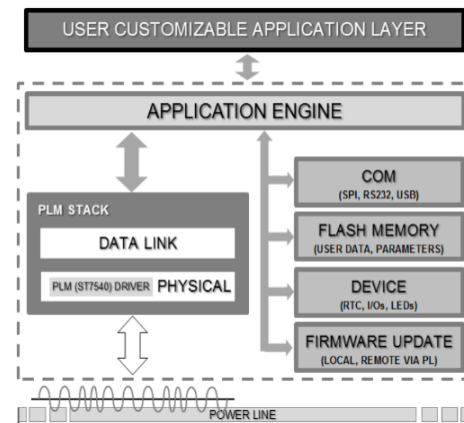
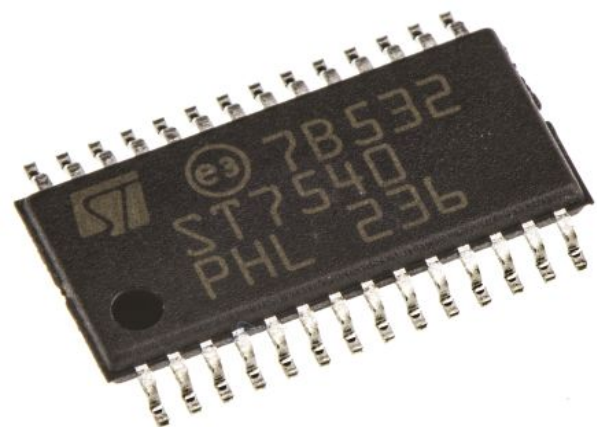

**Figure 3: PLM firmware structure**

The firmware structure is constructed by several layers, each managing a different feature. The User application is the program in which users can customize the code based on their demands. The Application engine is the general interface between the User application and all the parts of the module. It manages communication protocols (SPI, USART and USB), flash memory, real-time clock, GPIO (General Purpose Input Output), LEDs, and the RFU. Next, the PLM Stack itself is constituted of several layers. It implements the powerline communication, manages the conflicts of transmission, timing, addressing, and so on.

**3.3. FSK powerline transceiver: ST7540**

The ST7540 is a very low power consumption Half-Duplex synchronous/asynchronous FSK Modem designed for powerline communication network applications.



**Figure 4: FSK powerline transceiver: ST7540**

The ST7540 is the main modem that takes responsibility for communicating between PLM modules through powerline. So, we will illustrate in detail about how it works and why we choose this module in the project.



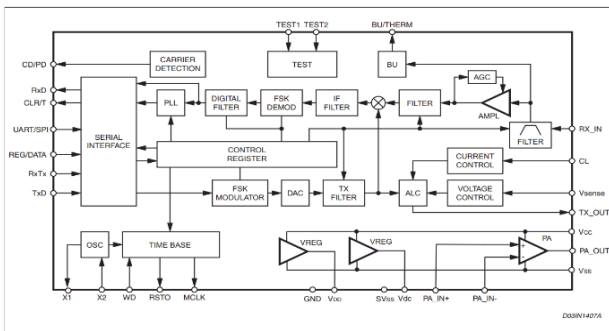

Figure 5: ST7540 – block diagram

**Main access:**

- Synchronous:
  - ST7540 manages the transmission timing and recovers the bit timing according to the BaudRate Selected.
  - Use: SPI interface
- Asynchronous:
  - The Host Controller manages the transmission timing and recovers the communication timing (CLR/T line should be neglected).
  - Use: UART

**3.4. Conflict avoidance mechanism: CSMA/CA**

CSMA/CA (Carrier-sense multiple access with collision avoidance) is a conflict avoidance mechanism using a back-off time and the “band in use” (BU). Before initiating any communication, each node waits until the band is free (check BU flag). As soon as the band is free, it calculates a random back-off time. When the back-off time is finished, if the band is still free, the transmission is started. Otherwise, repeating the loop.

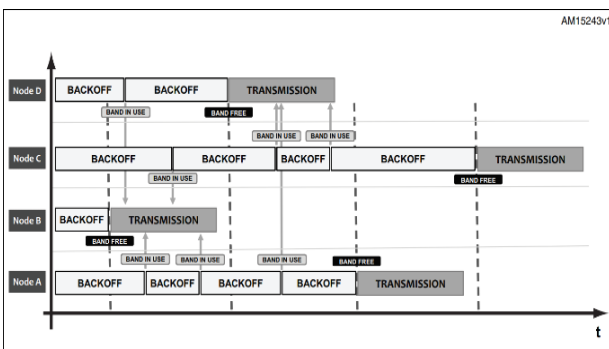

Figure 6: CSMA/CA mechanism

This mechanism assures that only one node can transmit data at a time, so there is no conflict between nodes in a network during the transmission time. However, it also has some disadvantages such as the only one band costs a lot of time if there are too many nodes in the network.

**3.5. FSK modulation technique**

FSK (Frequency-shift Keying) is a frequency modulation scheme which convert digital signal to carrier signal. It uses two difference carrier signals with two difference frequencies to represent

the original message signal. The carrier signal 1 represents the bit 1 and another one represents the bit 0.

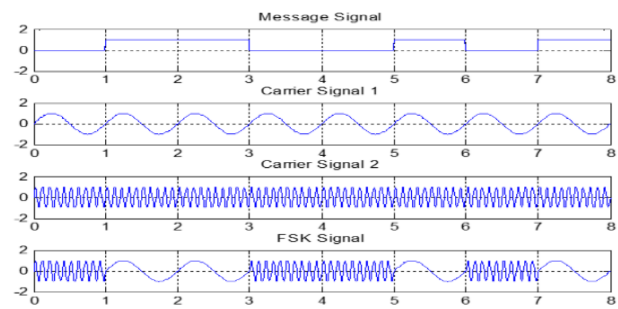

Figure 7: FSK modulation technique

**3.6. Transmission mode**

The original digital signal is converted to a carrier analog signal after going to the FSK modulation and DAC (Digital – to – Analog Converter). Then, it goes through a Band Pass filter which refines the signal with a specific frequency defined by 3 bits (0-2) of the Control Register. The signal passing the Band Pass filter will go to the ALC (Automatic Level Control) to control the transmission voltage and current. Finally, the PA module amplifies the signal before transmitting it.

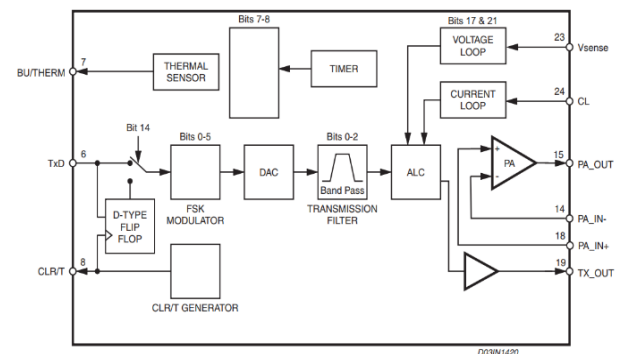

Figure 8: ST7540 – transmission mode

**3.7. Receiving mode**

The receiving signal comes with a lot of noises, so it has to go through a Pre-filter of 62 kHz. The signal itself with a very low SNR (Signal-to-Noise Ratio) is adapted by the AGC (Auto Gain Control) block which increases or decreases the amplitude of the waveform to balance the signal. Then, it is filtered by a Narrow Band bandpass filter and is down-converted by a mixer using a local oscillator to create an IF (intermediate frequency) signal. Because the signal after passing the Channel Filter has a smaller bandwidth, so if it wants to increase the SNR, it must be converted to a lower frequency signal. Then, the resulting signal is filtered by the IF Filter and demodulated to become a digital signal. Finally, the digital signal will pass the Digital Filter to remove noises from the baud rate frequency and reduce the signal Jitter.



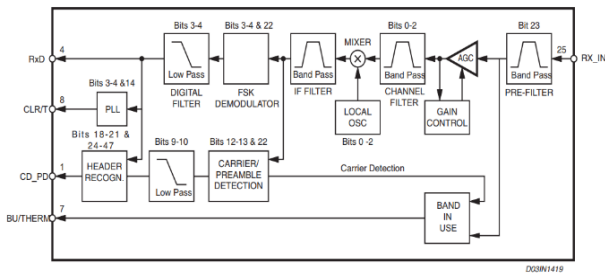

Figure 9. ST7540 – receiving mode

### 3.8. Transmission frame structure

If a user wants to control street lights from web application, a gateway has to connect to web server and there must be some ways so that the gateway can “understand” controlling signals from the user. So, we define a set of frame structure to communicate between the webserver and the gateway or between the gateway and nodes in a network.

#### 3.8.1. Connection frame

Connection frame is the first frame that web server sends to a gateway when it has just identified a new connection. Another role of the connection frame is that it contains server’s time to synchronize time of every PLM module installed in gateway and nodes. All the frames are designed in hexadecimal.

##### Frame structure:

```
uint8_t *buffer;
buffer[0] = Frame length; (E.g. 13)
buffer[1] = Hour; (E.g. 23h)
buffer[2] = Minute; (E.g. 35m)
buffer[3] = Second; (E.g. 00s)
buffer[4 → 12] = Message; (E.g. Connected)
E.g. “13 23 35 00 Connected”
To Hex → “0D 17 23 00 43 6F 6E 6E 65 63 74 65 64”
```

#### 3.8.2. Controlling frame

It is a main frame for controlling gateway and nodes turning on/off each light or a group of lights. Controlling frame uses a pre-defined frame of the PLM firmware, called Service frame (0x01) which is used for getting/setting output values, time clock, I/O configurations, firmware release information, and so on.

If a frame is broadcasting to every node, the Broadcast flag = 0x80, else, Broadcast flag = 0x00.

##### Frame structure:

```
uint8_t *buffer;
buffer[0] = Frame length; (E.g. 0x0C)
buffer[1] = Service frame | Broadcast flag; (0x01 | 0x80)
buffer[2,3] = Group address; (E.g. 0x154D)
buffer[4,5,6,7] = Node address; (E.g. 0x00000001)
buffer[8] = Service command; (Set output: 0x05)
buffer[9] = Output value; (On: 0x01; Off: 0x00)
buffer[10,11] = CRC16; (E.g. 0xC802)
```

#### 3.8.3. Schedule frame

This frame is used for setting up time for turning on/off street lights.

Schedule frame uses a pre-defined frame of the PLM firmware, called Data frame, which is treated on the User application layer.

##### Frame structure:

```
uint8_t *buffer;
buffer[0] = Frame length; (E.g. n+17 = 0x19)
buffer[1] = Data frame | Broadcast flag; (0x00 | 0x80)
buffer[2,3] = Group address; (E.g. 0x154D)
buffer[4,5,6,7] = Gateway address; (E.g. 0x00000001)
buffer[8] = Schedule ID; (E.g. 0x01)
buffer[9,10,11] = Time on; (E.g. hh mm ss: 0x17 0x28 0x00)
buffer[12,13,14] = Time off; (E.g. hh mm ss: 0x17 0x32 0x00)
buffer[15 → 15+n-1] = Node addresses; (E.g. 0x00000001 0x00000002)
buffer[15+n,15+n+1] = CRC16; (E.g. 0x66AF)
```

#### 3.8.4. Getting status frame

It is used for notifying webserver whether a light is on or off. This frame is sent periodically in broadcast mode to every node in the network so that light’s status in the web application is updated frequently. It also use the Service frame of the PLM firmware.

##### Frame structure:

```
uint8_t *buffer;
buffer[0] = Frame length; (E.g. 0x0B)
buffer[1] = Service frame | Broadcast flag; (0x01 | 0x80)
buffer[2,3] = Group address; (E.g. 0x154D)
buffer[4,5,6,7] = Gateway address (E.g. 0x00000001)
buffer[8] = Service command; (Input get: 0x04)
buffer[9,10] = CRC16; (E.g. 0xD3F1)
Excepting the Connection frame, all the other ones are added CRC16 (Cyclic Redundancy Check) before transmitted to ensure data integrity.
```

## IV. EVALUATION

##### Achievement:

- All street lights in a power grid are controlled directly by web application.
- By using FSK modulation technique, we reduce noises in transmission line to a minimum.
- One gateway can communicate with maximum 30 nodes so that the total delay time is less than 30 seconds.
- Transmission time between 2 PLM modules is less than 2 seconds.
- The difference of synchronization time between 2 modules is less than 0.5 seconds. So, every node which is set the same schedule time, turns on/off light concurrently.

**Limitations:**

- The connection time of GSM/GPRS module and the web server is slightly short (about 10 minutes). It is hard to figure out how long the timeout is so that it can try to reconnect.
- One of the disadvantages of PLC is that it is designed in half-duplex manner. This means data is transmitted in one direction at a time. If a PLM module wants to transmit data while another holds the band, it has to wait until the band is free.

**V. CONCLUSION**

Our research of the PLC technology shows that it is a great potential which can be applied in several areas. However, there are a lot of risks involved when starting to develop a new technology. However, we believe that PLC can replace many legacy protocols because the most reasonable benefit of PLC is that it use existing power grid to transmit data. Therefore, it helps to reduce cost of materials, installation and maintenance.

**ACKNOWLEDGEMENT**

We would like to give a special thanks to my supervisor Mr. Nguyen Duc Loi for his professional guidance and advices during the process of researching and implementing the project. We especially appreciate his assistance of supporting devices for our research.

**REFERENCES**

- [1] User manual - General purpose ST7540 power line modem module based on ST7540 PLM and STM32 microcontroller, <https://www.st.com/en/evaluation-tools/steval-ihp005v1.html#design-scroll>
- [2] ST7540 – FSK power line transceiver datasheet, <https://www.st.com/en/evaluation-tools/steval-ihp005v1.html#design-scroll>
- [3] <https://www.element14.com/community/docs/DOC-81033/1/general-purpose-power-line-modem-module-based-on-the-st7540-plm-and-stm32-microcontroller>
- [4] <https://uk.rs-online.com/web/p/modems-ics/6868215/>
- [5] <http://dostmuhammad.com/blog/tcp-connection-over-gprs-using-sim900-and-similar-modems-using-at-commands/>
- [6] What is Power Line Communication?, Cypress Semiconductor, [https://www.eetimes.com/document.asp?doc\\_id=1279014](https://www.eetimes.com/document.asp?doc_id=1279014)
- [7] User manual - ST7540 power line modem firmware stack, <https://www.st.com/en/evaluation-tools/steval-ihp005v1.html#design-scroll>

[8] ST-LINK On-Board | SEGGER – The Embedded Experts, <https://www.segger.com/products/debug-probes/j-link/models/other-j-links/st-link-on-board/>

[9] RS-485, <https://en.wikipedia.org/wiki/RS-485>

[10] Bluetooth, <https://en.wikipedia.org/wiki/Bluetooth>

[11] Lora, <https://en.wikipedia.org/wiki/LoRa>

[12] Zigbee, <https://en.wikipedia.org/wiki/Zigbee>

# Electricity Invoice System

**Duong Trieu Anh**  
FPT University  
HCMC, Viet Nam

**Hoang Nguyen Minh Giang**  
FPT University  
HCMC, Viet Nam

**Ngo Quang Duy**  
FPT University  
HCMC, Viet Nam

**Dang Manh Hung**  
FPT University  
HCMC, Viet Nam

## Abstract

*Electricity Invoice System, which helps users to solve current problems. Companies can manage invoices, proforma invoices, liabilities, customer's information; customers can get instant electronic invoices and manage these invoices easily. The use of HiEIS offers many practical benefits for businesses such as reducing printing, billing and shipping costs. The invoice is made on the computer and then sent to the tax office for authentication, the tax office returns the electronic invoice information with the authentication code for the enterprise. After the invoice is verified by the tax authorities, the company will transfer the electronic invoice to customers by electronic means such as: internet, email,...*

## Keywords

*HiEIS, E-Invoice, E-billing, Electronic Invoice, Pro forma invoice, Digital Signature*

## I. INTRODUCTION

In addition to the compulsory use of electronic invoices from 01/01/2018 of the government, there are many reasons that businesses should use e-invoices.

Nowadays, invoice management working in business is becoming more and more difficult because there are too many bills and complex documents that need to be processed. When customers want to see invoice information, they often have to wait for company's employees to send invoices to their house. This process can be very tiring and time-consuming.

Besides, companies always want to optimize time efficiency and productivity in order to bring their service to customers as quickly as possible.

Therefore, we are building a web application, which helps users to solve current problems.

## II. PROBLEMS AND SOLUTION

When customers want to see invoice information, they often have to wait for company's employees to send invoices to their house. This process can be very tiring and time-consuming.

In addition, companies always want to optimize time efficiency and productivity in order to bring their service to customers as quickly as possible.

## 2.1. Problem Definition

Paper processing or manual processing of invoices presents a number of challenges that result in unnecessary costs while reducing efficiency.

- **Time-consuming:** Huge amount of time spent on paper handling and data entry, manual cross-reference for validity. If the information is unavailable, they may have to send it to some other authorities for cross verification.

- **High chances of errors, fake invoices:** Paper invoices often lead to incorrect input and edit. Another limitation is that it is easy to be counterfeit.

- **Difficulty in monitoring, management:** Paper invoices get lost very easily. Monitoring each and every invoice is a tough task.

- **Waste of cost:** Companies spend a lot of money to print invoices. When they need to issue invoices to customers, especially customers that live far away, the company must use express delivery service.

## 2.2. Proposed Solution

There are many reasons that businesses should use e-invoices. Main reasons are as following:

- **Helping businesses save more time and money.** With e-invoices, businesses can save up time as well as cost associated with the use of paper invoices.

- **Authentic e-invoice is an effective solution to prevent false invoices.** When using a valid e-invoice, the business can issue invoices via email with no stamp. Verification signature on the invoice will help businesses create the trust of partners.

The proposed solution is to build a web application that allows companies to create and manage their own invoices, along with proforma invoices, easily. Customers of these companies are notified through email about invoices being issued by the system automatically and can even manage these invoices with their accounts. If customer is unable to pay for an invoice within month end, the system will automatically calculate customer's liabilities.

The proposed system is an electronic invoice system. The system contains a web application for guests, customers, accountants, managers, administrators and a winform application for reading company's digital signature.

In details, the system provides the following features:

For guests:

- Guests can lookup invoice or proforma invoice.

For customers:

- Customers can view all invoices and invoice details.
- Customers can view all proforma invoices and proforma invoice details.
- Customers can view liabilities and liabilities details.

For accountants:

- Accountants can manage invoice: create, edit, delete invoice, send email to customers. Moreover, payable accountants can confirm payment.
- Accountants can manage proforma invoice: create, edit, delete proforma invoices, send email to customers.
- Accountants can view customer's liabilities. Liability accountant can add payment.

- Accounting managers can approve performance invoices and sign invoices by digital signature.

For managers:

- Managers can manage product: create, edit, delete product.
- Managers can manage staff: create, edit, delete staff.
- Managers can manage template release: create template release, add and delete template blocks.
- Managers can manage customer: add existing accounts to company's customer list. Besides, they add products for customer.

For administrators:

- Administrators can manage company: create, edit, deactivate or activate, delete company.
- Administrators can manage account: create, edit, deactivate or activate, delete accounts.

The system can:

- Allow any users to lookup invoice or proforma invoice.
- Allow accountants to manage invoice, proforma invoice, liabilities.
- Allow manager to manage staff, product, template, customer.
- Allow accounting manager to sign invoice and approve proforma invoice.
- Allow administrator to manage company and account.

### III. PLAN IMPLEMENTATION

Feature functions:

- Guests can login if account is registered.
- System administrators can manage all companies and all accounts.
- Managers can manage their company's staffs, products, templates, customer list.
- Accounting managers can view and approve

proforma invoices, view and sign invoices with company's digital signature.

- Liability accountants can manage proforma invoices, invoices and customer's liabilities.
- Payable accountants can confirm payment for an invoice and add new payment.
- Customers of a company can search and download invoices and proforma invoices by using its lookup code; view liabilities.
- The system can automatically number invoices that meet deadlines; send email notification to customers when an invoice or proforma invoice is approved.

Our application is developed mainly on Entity Framework, which follows the MVC architecture with following components:

- Controller handles user interaction. Typically, controller reads data from a request, calls appropriate business method, selects and renders view for user.
- View is a user interface. It is responsible for rendering the model data and generating HTML output that client's browser can interpret.
- Model is responsible for managing data of the application. It responds to requests from view and also to instructions from controller to update itself. Model objects store and retrieve model state in a database.

We will also build a window application package containing operations to read digital signature and sign pdf at client.

#### Advantages of system:

- Efficient management: easy to lookup and manage invoice information, limit risks, simplifier preservation and storage.
- Cost saving: reduce the costs of printing, storing and transporting invoices; improve productivity and business efficiency; avoid burning, damaged, lost invoices.
- Time saving: minimize administrative procedures.
- Security: ensure accuracy and safety, avoid counterfeit invoices.

#### Disadvantages of system:

- E-invoices must have digital certificates, telecommunication infrastructure as well as other conditions from companies.
- Cannot invoke sign invoice function directly from web, but from window application.

## IV. ANALYSIS

### 4.1. Digital Signature:

A digital signature is a mathematical scheme for presenting the authenticity of digital messages or documents. A valid digital signature gives a recipient reason to believe that the message was created by a known sender (authentication), that the sender cannot deny having sent the message (non-repudiation), and that the message was not altered in

transit (integrity) [1].

#### 4.2. What is a digital certificate?

A digital certificate is an electronic document issued by a Certificate Authority (CA). It contains the public key for a digital signature and specifies the identity associated with the key, such as the name of an organization. The certificate is used to confirm that the public key belongs to the specific organization. The CA acts as the guarantor. Digital certificates must be issued by a trusted authority and are only valid for a specified time. They are required in order to create a digital signature [2].

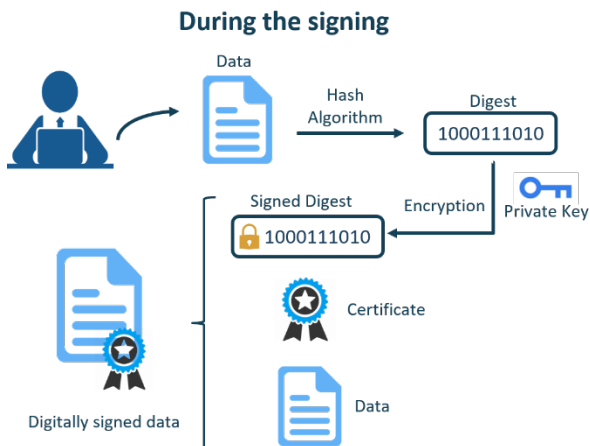

**Figure 1: Digital Signature - During signing**

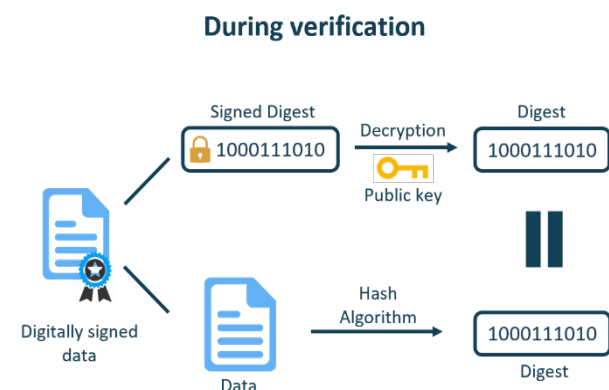

**Figure 2: Digital Signature - During verification**

## V. EXPERIMENT RESULTS AND CONCLUSION

We have executed some testing on our application. These are the results: successfully manage and publish invoices with digital signature; other management tasks also work smoothly.

After many experiments, we conclude that HiEIS is suitable and worth for invoice management.

### ACKNOWLEDGEMENT

This paper owes massive thanks to Mr. Ngo Dang Ha An at FPT University. He was always supporting us whenever we had problems developing this project. He consistently allowed this project to be our own work but steered us in the right direction.

## REFERENCE

- [1] Digital signature. Wikipedia. [Online] [https://en.wikipedia.org/wiki/Digital\\_signature](https://en.wikipedia.org/wiki/Digital_signature).
- [2] What are digital signatures? DocuSign. [Online] <https://www.docusign.com/how-it-works/electronic-signature/digital-signature/digital-signature-faq>.



# Design and Construction Sun Drying Wet Clothes System

**Hoang Phi Long**  
FPT University  
HCMC, Viet Nam

**Nguyen Dinh Phong**  
FPT University  
HCMC, Viet Nam

**Trinh Binh**  
FPT University  
HCMC, Viet Nam

## Abstract

Vietnamese have long working hours which means they spend time at evening and night to do their chores. The chores include washing and drying clothes. However, Vietnam also has long rainy season which indicate a persistent problem of inefficient clothes drying process.

## Keywords

Design and construction sun drying wet clothes system, Clothes drying system, Rain sensor, Internet of Things, React Native, ExpressJS, NodeJS, Automatic clothes-drying system

## I. INTRODUCTION

An automatic clothes drying system, which uses rain sensor to detect rain and ESP8266 for communications between Android application and embedded device, was developed to allow consumers to effectively manage their chores. This document will explain the foundations and the processes of this innovative system.

Furthermore, this document describes our working process in 4 months including our perspective in the system, component designs and detailed core work-flows. We hope the system will help resolve some aspects of the problem that the current face recognition systems are facing today.

## II. PROBLEM AND SOLUTION

### 2.1. Problem definition

Advantage of existing system on the market

- UV disinfection
- Built-in dryer
- Strong structure which can lift up to 25kg of clothes
- Drawbacks of existing system on the market
- High production costs which lead to relatively high selling prices
- Hard to extend
- Automation fully dependent on electricity
- Cannot automatically collecting clothes.

### 2.2. Proposed solution

Our proposed solution is to design and construct an automatic clothes drying system called DCDCS to solve missing feature of the current "Smart Clothesline Rigs". Our system will allow the automation of laundry-colleting in the case of rains.

Our system will also be competitively priced, easier installation, more compact and mobile, and extendable compare to the existing system. DCDCS system includes a mobile app and an embedded device with following functions:

### 2.2.1. Feature Functions

- Mobile App:
  - Control the system through wireless
  - Check weather information
  - Check system status
- Embedded Device:
  - Check system status
  - Control system through hard buttons

### 2.2.2. Advantages and Disadvantages

- Advantages:
  - Low costs which allow more affordable prices
  - Fast rain detection
  - Can control using mobile app
  - Use solar energy and store extra energy as battery for use under adverse conditions
- Disadvantages:
  - Cannot detect whether the clothes is dry or not
  - Cannot detect whether rain is over or not

## III. PLAN IMPLEMENTATION

### 3.1. Basic concept

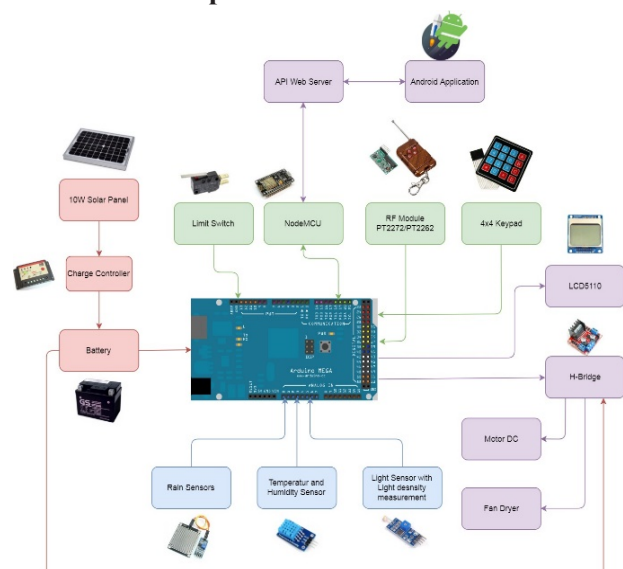

Figure 1: System block diagram

The block diagram above illustrates the underlying concept of the Automatic clothes-drying system. At first, the system will gather data from connected sensors. From collected data, the system will determine its own action to control the dryer or dc motor to collect or dry clothes. After that, the system will send all those data to the server via HTTPS request for the mobile application. Beside sensors data, the system can be controlled by RF Remote or Keypad on the system. About Mobile application, users can check system information with HTTPS request/response. To control the system with the mobile app, each time the user request an action; the mobile app will send a request to a server which is a message contains data to control the system. The server receives the message and pushes it to the message queue. Now, the system will ask each server for any messages from the system. If there is, the server will send the message via HTTPS response for the system. From the given message, the system now can control dc motor or dryer according to users' wants.

### 3.2. Architecture

#### 3.2.1. System overview architecture

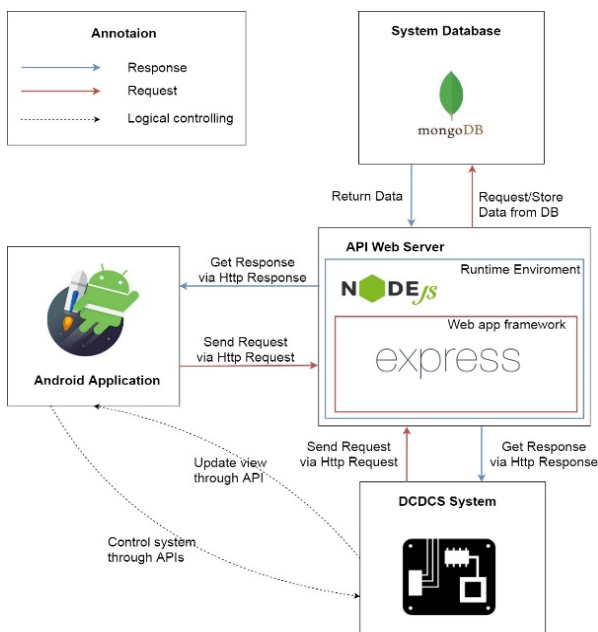

Figure 2: System overview architecture

#### 3.2.2. API Web server architectural design

In API development, the system is developed under MVC architecture style. We choose this architecture for API because of the following advantages:

- With MVC architecture, we can separate business code with Controller and View, so we can use the business code in API web server without repeating the code.
- It can eliminate the creation of the singleton and factory classes and well-defined interface to business layers.

- By separating concerns into 3 distinct pieces, we can perform unit testing easily. Our Presentation layer can be tested free of the Model or Controller, and vice-a-versa

- It supports all aspects of application development, business aspects, persistence aspects, etc., so we can develop a complete application.

This project follows MVC architecture with the following components:

- **Controller:** the part of the application that acts like event handler to handles user interactions. Typically, the controller reads data from a request and calls the appropriate business's method then selects the view to return to the user.

- **View:** The view renders the contents of a model. It gets data from the model and specifies how that data should be presented. It updates data presentation when the model changes. A view also forwards user input to a controller. Depending on the task being performed by the user the model can be looked at from different perspectives.

- **Model:** Represents the business data and any business logic that govern access to and modification of the data. The model notifies views when it changes and lets the view query the model about its state. It also lets the controller access application functionality encapsulated by the model. Typically, when a change in the model is to be reflected from user, it should be reflected in all the model's views.

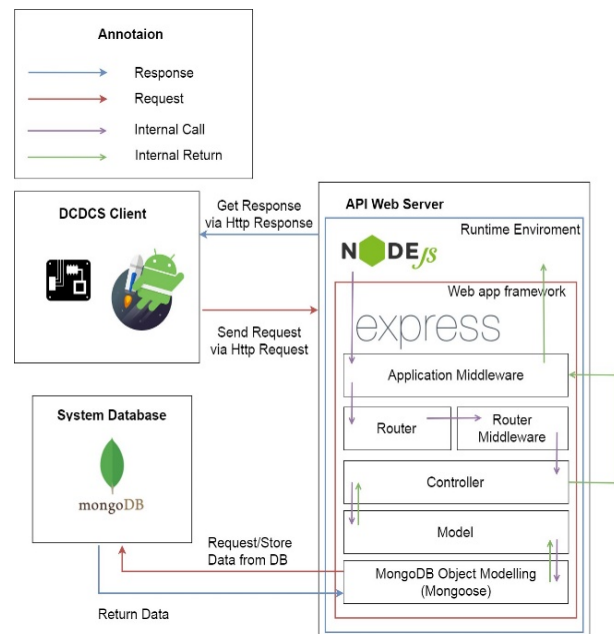

Figure 3: API Web server architectural design

#### 3.2.3. Hardware System Architecture

In Embedded Hardware control application, the system is developed under Internet of Things architecture style. We choose this architecture for Embedded Hardware control application because of following advantages:

- Highly scalable and available out of the box due to the nature of each selected component.
- Minimal knowledge required to start.
- It's scalable and fault tolerant by design.
- Reduces the development and deployment costs and timeframes

The system follows IoT architecture with following components:

- **Sensors and Actuators:** this part measures a physical quantity such as sound, temperature, moisture etc. and converts it into electrical quantity to make the system understand and act accordingly
- **Connectivity (NodeMCU):** The received signals are to be uploaded on the network using different communication medium such as Wi-Fi, Bluetooth or BLE, LoPAN etc.
- **People and Processes:** Networked inputs are then combined into bidirectional system that integrate data, people and processes for better decision making.

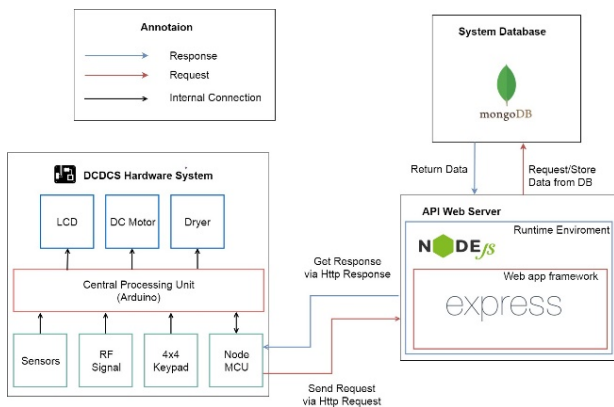

Figure 4: Hardware System Architecture

### 3.2.4. Mobile Application Architecture

In Android application, the system is developed under Flux architecture. We choose this architecture for Android Application because of following advantages:

- Flux is all about controlling the flow inside the app—and making it as simple to understand as possible.
- Easy to implement and understand. Hence it makes source code easier to maintain and reduce time to develop application
- Having supported library (Redux)
- Suitable for React Native codebase

Android Application follows Flux architecture with following components:

- **Actions:** Helpers that pass data to the Dispatcher. Are simple objects with a type property and some data. For example, an action could be: `{“type”: “IncreaseCount”, “payload”: {“delta”: 1}}`
- **Dispatcher:** Receives these Actions and broadcast payloads to registered callbacks. Acts as a central

hub. The dispatcher processes actions (for example, user interactions) and invokes callbacks that the stores have registered with it. The dispatcher isn't the same as controllers in the MVC pattern—usually the dispatcher does not have much logic inside it and you can reuse the same dispatcher across projects

- **Stores:** Contain the application's state and logic. The best abstraction is to think of stores as managing a particular domain of the application. They aren't the same as models in MVC since models usually try to model single objects, while stores in Flux can store anything. The real work in the application is done in the Stores. The Stores registered to listen in on the actions of the Dispatcher will do accordingly and update the Views.

- **Views:** are controller-views, also very common in most GUI MVC patterns. They listen for changes from the stores and re-render themselves appropriately. Views can also add new actions to the dispatcher, for example, on user interactions. The view are usually coded in React, but it's not necessary to use React with Flux.

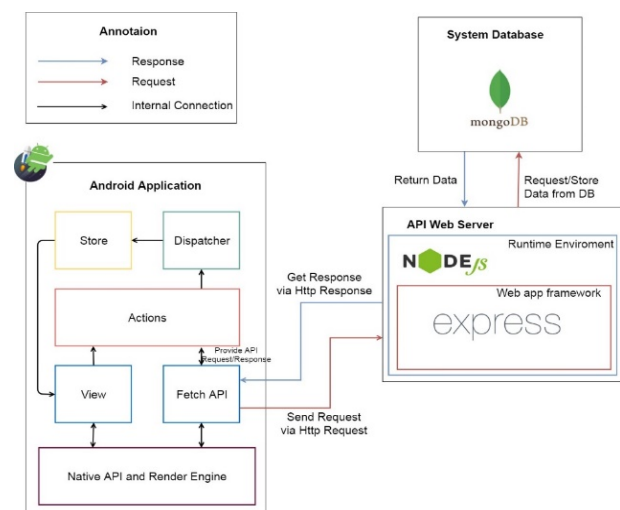

Figure 5: Mobile Application Architecture

## IV. ALGORITHMS AND DATA STRUCTURES

### 4.1. System control

#### 4.1.1. Definition

System has many ways to control the system; i.e. RF Remote, Android application, hardware button. From these controllers, they can control many another devices like DC Motor to collect or dry clothes.

#### 4.1.2. Define Problem

While using multiple controller at the same time. It causes a collision that leading to the system doesn't work correctly.

#### 4.1.3. Solution

We use one thread and blocking I/O to sequentially reading each controller. Therefore, when we're

handling a single controller. Another controller will be ignored.

**4.1.4. Pros & Cons**

- Pros:
  - No more collisions
  - Easy to control because the system now works on priority of the controller
  - Easy to extends when there are new controller
  - Memory reduced due to using only a single thread
- Cons:
  - An action takes longer time than user to complete (due to the priority)

**4.1.5. Algorithm Complexity**

- Time:  $O(n)$  with  $n$  is the number of controller
- Space:  $O(1)$  because we don't use any additional spaces

**4.1.6. Overview Flowchart**

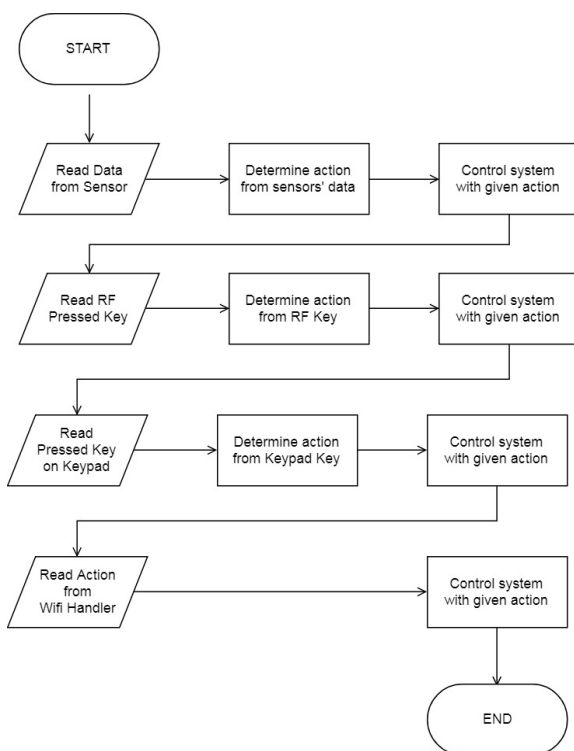

**Figure 6: System Control overview flowchart**

**4.2. Message Queue**

**4.2.1. Definition**

System can receive control message from multiple mobile application. Each mobile device can send multiple action including Get system data, Control DC Motor, Control dryer, etc. Also, each mobile device can control different system. This leading to a big problem about communication between mobiles and systems.

**4.2.2. Define Problem**

While the message is being sent to the server, the server will store it in a database. However, the order of the message is not sorted. Therefore the server doesn't know which message should be sent first and later.

**4.2.3. Solution**

We will build a queue for each device id, naming it as a message queue. In this queue, a message will have a priority note and timestamp along with another data. In order to send a message, the server will sort all messages in the queue by priority and then by timestamp. If 2 messages have the same priority then the one which comes earlier has higher order. If 2 messages have same priority and timestamp, they will be sent in random order. For any messages in queue longer than 30 seconds will be deleted.

**4.2.4. Pros & Cons**

- Pros:
  - No more collisions
  - Handling message is easier due individual device queue
  - With priority, user can force system do a certain action with very high priority
- Cons:
  - Some message unable to send due to time limitation and priority

**4.2.5. Algorithm Complexity**

- Time:
  - $O(n \log n)$  for sorting algorithm.
  - $O(1)$  for adding message to queue
  - $O(1)$  for getting a message from queue
  - Total:  $O(n \log n)$
- Space:  $O(n)$  if database use indexing for faster sorting and searching.

**V. PERFORMANCES**

**5.1. Control System from Android App Performances**

**Request time performance**

Network Type	System	Request Time
Wi-Fi (Ping 2, Down: 20Mb, Up: 15Mb)	Android Application	143ms
Wi-Fi (Ping 2, Down: 20Mb, Up: 15Mb)	DCDCS System	252ms
3G	Android Application	471ms

**Table 1: API request performance**



**Response time performan**

Network Type	System	Request Time
Wi-Fi (Ping 2, Down: 20Mb, Up: 15Mb)	Android Application	352ms
Wi-Fi (Ping 2, Down: 20Mb, Up: 15Mb)	DCDCS System	461ms
3G	Android Application	621ms

**Table 2: API response performance****5.2. Control System from RF Remote/Keypad**

Control Type	Distance	Response Time
RF Remote	0m	5ms
RF Remote	50m	32ms
RF Remote	100m	182ms
Keypad	0m	5ms

**Table 3: RF Remote/Keypad performance****VI. EVALUATION****Achievement:**

- System can be controlled via mobile phone
- System can detect rain within ~50ms.
- Server can handle at least 1000 request per second.
- System is easy to construct.
- System works with 95% accuracy.

**Limitations:**

- Cannot determine whenever clothes is dry or not.
- Cannot determine wherever rain is stopped or not
- Cannot control via Web application

**Further Suggestions:**

- Implement Hidden Markov Models (HMM) for rain forecasting
- Implement the ability to detect when the rain stop using HMM
- Build a website for user to check their account information and control the system along with mobile application
- Build a system that can detect whenever the clothes is dry or wet.

**VII. CONCLUSION**

Our research of the DCDCS system shows that it has a great potential to succeed in the market. However, there are some limitations to the system such as the fact that its inability to detect rain using Mathematics process. These limitations need to be improved to make customers more willing to buy our product as well as giving the product a competitive advantage over other competitors.

**ACKNOWLEDGEMENT**

We would like to give a special thanks to my supervisor Mr. Nguyen Duc Loi for his professional guidance and advices during the process of researching and implementing the project. We especially appreciate his assistance of supporting devices for our research.

**REFERENCES**

1. Flux Architecture: <https://facebook.github.io/flux/>
2. How Expo Works: <https://docs.expo.io/versions/latest/workflow/how-expo-works>
3. React Native Mechanism Explanation: <https://wetalkit.xyz/react-native-what-it-is-and-how-it-works-e2182d008f5e>
4. Understanding Node.js & Express.js: <https://medium.com/@LindaVivah/the-beginners-guide-understanding-node-js-express-js-fundamentals-e15493462be1>
5. Understand Express: <https://evanhahn.com/understanding-express/>
6. The 4 stages of an IoT architecture: <https://techbeacon.com/4-stages-iot-architecture>



# Get a Tour Guide near Tourists

**Nguyen Bui Hoang Minh**

FPT University  
HCMC, Viet Nam

**Doan Bao Quyen**

FPT University  
HCMC, Viet Nam

**Le Thien Duy**

FPT University  
HCMC, Viet Nam

## Abstract

*At the present, the tourist usually uses traditional ways to book tour, that is they have to go to travel company to book tour. But that solution has a few problems such as lose too much time to find a tour has visit places they want to go or they don't know reputable tourism company.*

*Another way to solve this problem for tourist and tour guide is Tour Planner. Tourists just need to use mobile application on their smartphone. In addition, tour guide, local people are knowledgeable about culture and places of tourism also need to use mobile application to accept tours from tourists.*

*That is the reason why we decided to build a mobile application Tour Planner not only help tourist saves time and cost to book tour but also helps tour guide, especially freelance tour guide accepts tour and sends suggestion plan. When tourist needs to book tour system will give the most convenient schedule. In addition, tourist can receive suggestion schedule from tour guide and tourist can follow their trip.*

## Keywords

*Make plan automatically, Tracking tour*

## I. INTRODUCTION

Tour planner on mobile application for is the system we build to provide booking tour services for the tourist and receive tour services for the tour guide. Our approach contains a main problem create most convenient plan for tourist.

Booking tour services is the way we allow tourists choose visit places, then they will have the most convenient plan and they will send that plan to whole tour guide in same city they want to visit. To do that we need to have a lot of information of visit places. When tourist books tour, our system will send notification to all tour guide who use tour guide mobile application and they will receive that tour.

In details, we build booking tour service with the following work-flow:

- After tourist having chosen visit places, we will send that visit places to system.
- Then our system will compute the most convenient.
- Next step, system will calculate price for tour.
- System will send plan and price for tourist.

## II. PROBLEM AND SOLUTION PLAN

When we start to identify problems and find the way to resolve them, we found many difficult things. First we decide to deploy Open Source Routing Machine (OSRM) to independent server to find shortest path to over all places. When we had a way to find shortest path, we instantly face with another problem that we can't extend their code. So we fail on this way.

## III. PLAN IMPLEMENTATION

### 3.1. Pre-processing and Data Structures

### 3.2. Algorithm

#### 3.2.1. Make plan automatically

After tourist chooses visit places for their trip, we need to create the most convenient plan for tourist. The plan after make will include restaurants that are places for tourists to have meal. To implement this algorithm, we use information about latitude, longitude and limit time to visit of places and information about address of restaurants.

The processing model of making plan following these steps:

- First system will get distance between visit places that tourist was chosen by call Google Map API [1] with type Distance Matrix. Distance between places are calculated based on real streets for car.
  - After having distance between visit places, we will find all permutations of visit places have limit time to visit smaller 7 hours. Visit places with limit time equal or more 7 hours will go on 1 day.
  - Each element of permutations we will calculate total distance. Element have smallest total distance is the shortest path over all places.
  - Separate places for each day. Maximum hour per day for travel is 12 hours.
  - Restaurant will be added between two places in time between 11h and 14h.
  - Estimate price will be calculated bases on formula:  
**Price = Total\_Distance \* Price\_Per\_Km + Day\_Number \* Price\_Per\_Day**
- Detail description:
- Price: price of all tour per person.
  - Total\_Distance: total distance tourist has to go all trip, unit is kilometer.
  - Day\_Number: the total day tourist will spend for their trip.

- Price\_Per\_Km: the price per kilometers tourist needs to go.
  - Price\_Per\_Day: the income of tour guide per days.
- Figure 1 shows flow of make plan.

### 3.2.2. Tracking tour

After tourist going to specific place, tourists need to be known where they are going. In addition, this is the basis for the formation of invoice between tourist and tour guide. System will track place when tourist go there. To implement this algorithm, we use information about current latitude, longitude of tourist or tour guide.

The processing model of tracking tour following these steps:

- First system will get current tours, current time is between start time and finish time of tour.
- In each tour, system will get place tourist have to go in current time.
- System will get current coordinate of tourist and tour guide. System will calculate distance between tourist and current place and distance between tour guide and current place.
- If distance between tourist and current place or distance between tour guide and current place is smaller 500 meters, system will track that place.

## IV. ANALYSIS

### 4.1. Make plan automatically algorithm

#### 4.1.1. Get shortest path

After tourist input address to start tour and visit places system will get latitude and longitude of address of start tour and visit places. Then our system will call Google Map API with type Distance Matrix to get distance between its.

#### 4.1.2. Separate places to each day

After system has distance between visit places and address to start tour system will separate visit places to each day.

First system will set each place with limit time to visit greater than or equal 7 hours for each day. After than system find all permutations of visit places have limit time to visit smaller 7 hours. With each case of permutations system will find total distance and get element with shortest path.

After that system will traverse all visit places in shortest path. System will get each place in this path then add to day. If total time to visit of current day equal or greater than 7 hours system will add more day. Next system will merge all days together into plan.

#### 4.1.3. Add restaurant to each day

Based on plan was made, system will add restaurant for each day. Restaurants will be added between two places in time between 11h and 14h. System will find restaurants nearest place they visited.

### 4.1.4. Performance

Test environment:

Server side:

Hardware	Specification
Internet Connection	Cable 60 Mbps
Operating System	Ubuntu 14.05
CPU	Intel Xeon Processors
Memory	8GB

Test case:

No.	Start Address	Number of places	Network
1	Innovation Building,	5	Wifi (55 Mbps)
2	District 12,	6	
3	Ho Chi Minh City	7	

#### 4.1.4.1. CASE 1

- We will test response time of make plan for tourist with number of places is 5

Test No.	Average Response Time (millisecond)	Execute date
1	761	8 Aug 2018
2	677	8 Aug 2018
3	507	8 Aug 2018
4	743	8 Aug 2018
5	603	8 Aug 2018
6	726	8 Aug 2018
7	707	8 Aug 2018
8	694	8 Aug 2018
9	667	8 Aug 2018
10	739	8 Aug 2018

#### 4.1.4.2. CASE 2

- We will test response time of make plan for tourist with number of places is 6

Test No.	Average Response Time (millisecond)	Execute date
1	1373	8 Aug 2018
2	1108	8 Aug 2018
3	1195	8 Aug 2018
4	1278	8 Aug 2018
5	1035	8 Aug 2018
6	1151	8 Aug 2018
7	1153	8 Aug 2018
8	1148	8 Aug 2018
9	1083	8 Aug 2018
10	893	8 Aug 2018

**4.1.4.3. CASE 3**

- We will test response time of make plan for tourist with number of places is 7

Test No.	Average Response Time (ms)	Execute date
1	1401	8 Aug 2018
2	1442	8 Aug 2018
3	1096	8 Aug 2018
4	1117	8 Aug 2018
5	1271	8 Aug 2018
6	1274	8 Aug 2018
7	1094	8 Aug 2018
8	1130	8 Aug 2018
9	1141	8 Aug 2018
10	1092	8 Aug 2018

**4.2. Tracking tour**

**4.2.1. Get current place in current time**

Basing on current time system will get place where tourist is visiting or will visit. After that system will get latitude and longitude of that place.

**4.2.2. Get latitude and longitude of tourist and tour guide**

System will get current latitude and longitude of tourist and tour guide of tour.

After that system will calculate distance between

current place and tourist.

- If distance of tourist and current place smaller than 500 meters system will update status of that place. That means place was visited.

- If distance of tour guide and current place smaller than 500 meters system will update status.

**V. EXPERIMENTAL RESULTS AND CONCLUSION**

Our system provides services for tourists that help them to book tour easier, save the time. Moreover, our system provides services for tour guides and local people that help them have more income when they are free. Besides, this is a solution for freelance tour guide.

**ACKNOWLEDGMENT**

We are want to send a big thanks to our advisor, Mr. Kieu Trong Khanh. About his idea and the way he guides us, leads us to overcome difficulties in this project. We learned a lot from these things and we appreciate about all of this. Once again We want to thank him and look forward to working with him.

**REFERENCES**

[1] Google Map API Document “<https://developers.google.com/maps/documentation/>”

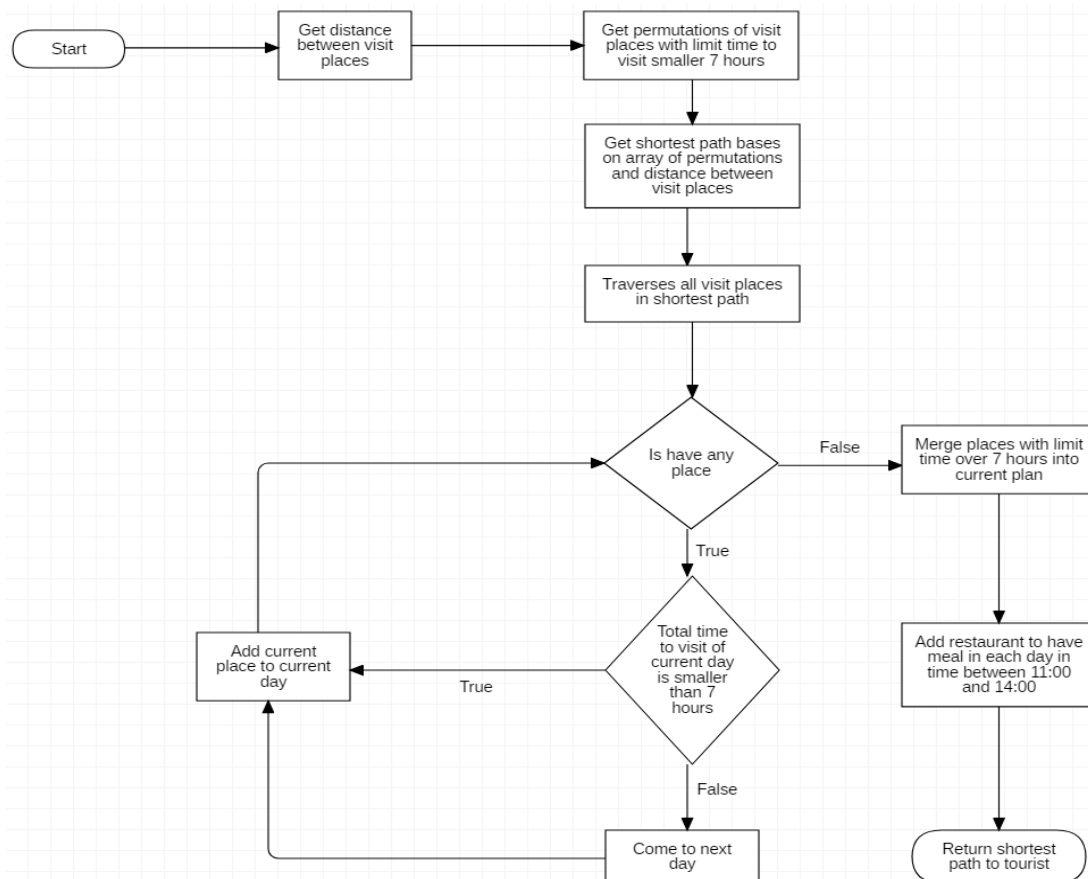

**Figure 1. Flow chart of make tour plan automatically**

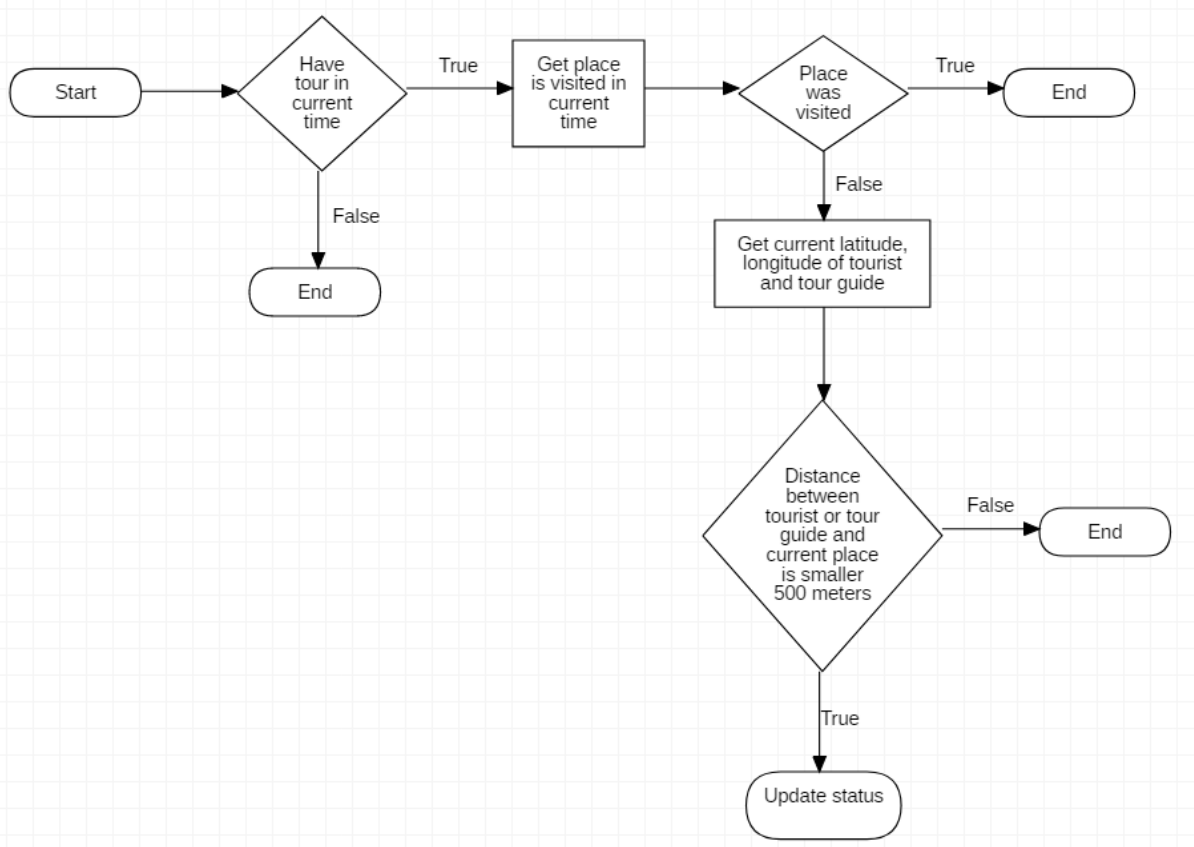

**Figure 2. Flow chart of tracking tour**

# Human Resource Sharing for Software Company

**Nguyen Nhat Ha**  
FPT University  
HCMC, Viet Nam

**Ho Thai Thien**  
FPT University  
HCMC, Viet Nam

**Vo Cong Phuc**  
FPT University  
HCMC, Viet Nam

**Pham Tran Anh Tu**  
FPT University  
HCMC, Viet Nam

## **Abstract**

*Software Engineering is rapidly developing in Vietnam from nowadays. Along with that, many software companies are founded with the main concentration is to develop outsourcing project only, which drives them to many unseen problems. One of the problems that most outsourcing software company is currently facing is that they have to pay their human resources, who have too much time to kill after finished a project. In the other hands, a lot of companies have to face situation in which they don't have enough human resource to run the project properly, and they don't know where to find the appropriate substitutions. Having realized the problem, we has decided to develop a software system to help both sides to solve their problem.*

## **Keywords**

*Human Resource Sharing, Software company*

## **I. INTRODUCTION**

In recent years, outsourcing has become more and more trendy. It is a fact that so many software companies are founded nowadays with the main regard is to outsourcing rather than making a product. In outsourcing companies, there are time frames when human resources (developer, project manager, QC...) are free, waiting for new project. These time frames may last for very long time (for months), and the company still have to pay for those free resources. In the other hand, there are also companies that seriously need resource for their project at the same moment.

We build a system which provides a peer-to-peer channel. It allows the resource-free companies to post profiles of their resources (including basic info, skill, experience...) that available for leasing. In the other hand, the resource-lack companies also can find resource by posting resource requests (including required skills, domain, and amount of resource...). The system will then perform matching, so that the companies can find each other and solve their resource problem. Feedback is also an important feature that the system will provide user, which can help improving the sharing environment.

## **II. PROBLEM AND SOLUTION PLAN**

When implement the system, we faced several problems:

### **2.1. The short-term resource hiring marketplace has still not available**

In this project, we put our concern about developing a human resource leasing environment to solve the free human resource problem in outsourcing companies, as well as the lack of human resource in the other side. We has named it Human Resource Sharing for Software Company (HRSSC).

In current time, in Vietnam, as well as in developed countries, there are systems which allow companies to post their recruitment news and then wait for candidate to apply. For example, the website vietnamwork.com allows companies to write down some very basic information about their desired candidate and publish it to find resource. Those recruitments news is usually to recruit long-time demanding resources, who are not going to leave the company as soon as the project is done. One more thing is they are not focus on any specific kind of career, it's just as many career as possible. For the reasons mentioned, those system cannot satisfy what they need at the moment, everything is still the relationship story. What software outsourcing companies currently need is a system helps them to solve their short-time demanding human resource problem.

Our solution is to provide a system for all software outsourcing corporations, especially the Vietnam companies an environment only focus on hiring and leasing temporary human resource, who come to work and leave in a short time. With this system, all their demands of recruiting temporary software human resources as well as leasing their free human resource in short time are well satisfied.

### **2.2. The peer-to-peer management problem**

The system goal is to provide an environment that allows the software corporation to interact with each other, which mean it create a peer-to-peer channel between them. From what I have mentioned above, the system may sound like a social network, in which someone post something and wait for interaction from other such as comment, like, dislike... But those actions are for the true form of social network



like Facebook or Instagram. Instead of like, comment or something like that, the HRSSC system should allow user to interact with each other through some more specific actions. For example, a company has a free resource, and the resource manager want to find and assign him to a project from another company. So, the system must provide the function for the manager to find, and assign that resource to the project. It's easy for us to imagine how it works in the non-software environment. But this is a software system, just with those two simple actions, a lot of management problem have to be handled.

Acknowledge the difficulty, we has planned to provide user the tools to manage the interactions between them (or between their properties) such as Resource Management, Project Management, Invitation Management, Appliance Management....

### 2.3. The guarantee of human resource quality

The human resource quality is an importance aspect that the corporations should pay much attention. Assume that there are many software corporations join in the system, which mean the human resource is come from anywhere, with any level of skills and personal characteristics. It's the fact that there will be the good and the bad one exists in the system. The biggest question of user is how to indicate who are bad, and who are good. Nothing can guarantee that a user can always found the good human resource.

We have discussed and decided to publish some user constraint for the problem. First, any software company wants to join in the system must prove that it a real corporation. By doing that, we can control the human resource quality easier. We also provide user the human resource feedback and rating feature. The feature have no guarantee that user can get a good human resource anytime. But at least, it can help user to make better hiring decisions.

### 2.4. The recommendation system

When a user join and use the system, he may not get the expected result. For example, a manager has a resource with good English skills and have experience in management process, which indicate that he is most suitable for management jobs. But the manager have difficulty in finding him a project with requirements that fit him just by searching around in the system. The manager may feel inconvenient and unhappy for that.

As the problem mentioned above, the system needs a recommend system, which recommend the suitable things for the manager depend on what he's got. For example, if the manager has posted a project to find resource, the system should recommend him a list of resource base on the project requirement, and the resource's experience. It is going save a lot of time of the manager using this feature.

## III. PLAN IMPLEMENTATION

### 3. 1. MVC Web Application and Spring framework

Considering the system characteristic, which is mentioned above, we has decided to implement the system as a web application using MVC Model for the following advantages:

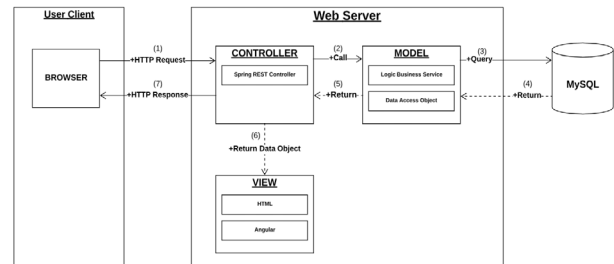

Figure 1: MVC model

- Every component in MVC model (Model, View, and Controller) is a separate component, whose meaning is clear as its name. So, the abstract view of the system become clear to everyone, which is going to help us a lot in the development phase.
- Separate the system into components also helps us to test it easier.
- Any component can easily be replaced without or with little impact to other components, so it reduces the effort to maintain the system.
- Rapid development process: MVC supports quick, parallel development process. Using MVC, the team can flexibly assign task for teammates. While a person is working on the view side, another one can separately work with the business logic on controller to create business logic of the web application. It reduces a lot of time spending for development phase.

In mean time, Java Spring family is one of the most powerful frameworks which support MVC Design Pattern. Spring MVC, Spring Boot, Spring JPA, Spring Hibernate and Spring Security are the frameworks we are going to use in this project.



### 3.2. System abstract business and management tools

First of all, the company representative must prove that his corporation is a real one first before we can provide him an account representing his company.

The two main entities in the system are the human resource, which is internally called "resource"; and the resource request, which we call it "project".

A company can have two kinds of account: Chief account is the most powerful account of that company; and Manager account is created and managed by the Chief, and can only access to Resource and Project Management tools. A Chief is allowed to perform all

the Manager’s action, in the other words, a Chief is a super Manager.

A Manager can manage a group of resources or projects by using the CRUD management tool for each kind. The manager can “invite” a external resource to work in his project, or he can “apply” his resource to work in a project from another company. An entity called “contract” is involved in the apply/invite procedure. It may help the two corporations to discuss the agreement terms. A chat channel between the two Manager is also enabled then, which can help them to communicate better.

**3.3. The Matching Algorithm**

Whenever a project or human resource profile is created or updated, system implicitly performs the matching function. The goal of this matching function is to find the resources who are best match with this project (or vice versa) bases on both side profile, so that the project manager make decision to invite a matched resource to his project, or to apply his resource to the matched project.

From a given human resource and a given project, calculate the similarity between the two bases on followings criteria:

Matching Criteria	
Project side	Resource side
Skill Requirements	Resource Skills
Domain of this project	Domains that this resource has worked in.
Type of this project	Type of project that this resource has done before.
N/A	Average Rating
Project Schedule Time	Resource Schedule Time

**Table 1: Matching Criteria**

**Skill:**

- Skill: A human resource profile should contain one or many skills. Each skill goes with a float number that point out the years of experience of the resource with that skill. The longer the resource has been working with the skill, the higher the float number.
- A project requirement contains one or many skills. Same as human resource profile, each skill also goes with a float number experience in year, which mean the project requires the joining resource to have that amount of year working with the skill.

**Domain:**

- A project details should describes which domain the project belongs to. For example: Education, Security, Game...
- A human resource may have worked on zero or more project (in the system). Each project has its own domains.

**Type:**

- A project is implemented in one or many type of platform. For Example: Mobile, Web...
- A human resource may have worked on zero or more project (in the system). Each project has its own types.

**Time:** A resource available time should match more than 50% with the time the project may run.

**Rating Score:** Every human resource is rating by the project manager right after the project is finished. The higher the rating, the more likely resource is matched to the project.

The matched score is a float number, the more similar between the two entries, the higher the score. The matched score is calculated as the formation below: Assume that:

$$A = \text{ratio of Similarity Score} = 0.7$$

$$B = \text{ratio of Rating Score} = 0.3$$

$$\text{Matched Score} = A \times \text{Similarity} + B \times \text{Rating}$$

When: **Similarity Score = Skill + Domain + Type**

**Skill Score:** This is the most important score in the formation, if this score equals zero, the Similarity Score is considered as “0”, regardless how high the other scores is.

So, at first, we must find the similar skills between the two entries (Resource and Project).

- If there is no similar skill, the skill score is set to “0”, which mean the Similarity score is also set to 0. Ignore all the other scores.

- If there is one or more similar skill, we calculate the Skill score as below:

$$\text{Skill Score} = \text{Base Skill Score} \times \text{multiplier}$$

Base Skill Score = 5.0 (default)

Multiplier = Product of all Skill Ratio’s Value (depend on the number of similar skills).

$$\text{Skill Ratio} = \frac{\text{Resource.Skill.experience}}{\text{Project.Skill.experience}}$$

Multiplier base on Skill Ratio	
Skill Ratio (x)	Ratio Value
$x < 0.8$	1
$0.8 \leq x < 1$	1.2
$x = 1$	2.2
$1 < x \leq 1.3$	1.5
$1.3 < x \leq 1.6$	1.2
$x > 1.6$	1

**Table 2: Multiplier base on Skill Ratio**

**Domain Score:** As mentioned above, every project has its own set of domain; every resource may have worked on zero or more project before. All we need to do is to find all those resource’s project and compare the set of domain.

At first, find the similar domain between the matching project and each of the resource’s history project.

For every similar domain, just simply increase the Domain Score by Base Domain Score.

Base Domain Score is by default 2.0.

**Type Score:** Same as the Domain Score, We find the similar Type between the matching project and the history project of the resource.

For every similar domain, just simply increase the Type Score by Base Type Score.

Base Type Score is by default 2.0.

**Time Score:** this score is calculated as the following figure:

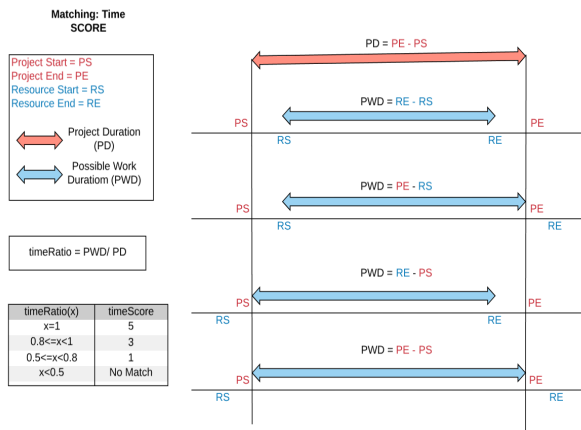

**Figure 2: Time Score Formation**

**IV. EXPERIMENT RESULT AND CONCLUSION**

Data Sample:

[https://drive.google.com/open?id=1ybb3v8Vxq-FxY5yYIu2RER6rXSkx\\_CdD0PhaqQk1tnc](https://drive.google.com/open?id=1ybb3v8Vxq-FxY5yYIu2RER6rXSkx_CdD0PhaqQk1tnc)

**Resource B – Project A:**

Similar Skills: Java, TOEIC, Android

Similar Domain: N/A => Domain Score = 0

Similar Type: N/A => Type Score = 0

Ratio Java = 3/3 = 1 => Java multiplier = 2.2

Ratio TOEIC 700/700 =1 => TOEIC multiplier = 2.2

Ratio Android = 2.5 / 3 = 0.83 => Android multiplier = 1.2

Skill Score = 5.0 \* 2.2 \* 2.2 \* 1.2 = 29.04

Similarity score = Skill + Domain + Type = 29.04

Matched score = Similarity \* 0.7 + Rating \* 0.3 = 29.04\* 0.7 + 3.5 \* 0.3 = 21.378

We have executed some testing on our application, below are the results:

Matching Testing Result		
Project	Resource	
A	B	21.378
	C	13.24
	D	7.2
	E	0

**Table 3: Matching Testing Result**

**CONCLUSION**

After repeated testing on many sample of data set, the result is as we expected. Sometimes error occurred for some exception case, we are still working to resolve those case.

**ACKNOWLEDGMENT**

This paper owes massive thanks to Mr. Nguyen Huy Hung of FPT University, who always feels ready to give useful advises to us for every difficulty we have met in every stage of the HRSSC system development process.

**REFERENCE**

1. Spring Framework 5.0.7 [Online.] Available: <https://spring.io/projects/spring-framework#overview>. Accessed on: Jun. 2018.

# Conference Participants





**Doan Kim Loan**

Student at HCMC FPT University  
loandksb60924@fpt.edu.vn

**Students of Business Management Faculty,  
HCM FPT University**

**Diep Phuong Thanh**

thanhdpsb60999@fpt.edu.vn

**Dinh Trung Hieu**

hieudtsb60937@fpt.edu.vn

**Lai Thi Thao My**

myltsb60985@fpt.edu.vn

**Pham Huynh Vinh Phuong**

phuongphvsb60978@fpt.edu.vn

**Phan Duc Minh**

minhpdsb61111@fpt.edu.vn

**Hoang Thi Tu Anh**

anhhttsb60989@fpt.edu.vn

**Trinh Thi Yen Anh**

anhhtysb60909@fpt.edu.vn

**Huynh Tieu My**

myhtsb60934@fpt.edu.vn

**Nguyen Duc Duy**

duynds60896@fpt.edu.vn

**Luong Nhat Duy**

duylnsb60965@fpt.edu.vn

**Tran Xuan Duc**

dactxsb60819@fpt.edu.vn

**Doan Thi Thanh Giang**

giangdtsb60930@fpt.edu.vn

**Duong Huynh Thao Nguyen**

nguyendhtsb60950@fpt.edu.vn

**Vo Van Thanh Nhat**

nhatvvtb60958@fpt.edu.vn

**Le Thu Huyen**

huyenltsb60971@fpt.edu.vn

**Huynh Gia Thuy**

thuyhgsb60975@fpt.edu.vn

**Pham Tien Tung**

tungptsb60913@fpt.edu.vn

**Tran Hong Ngoc Thuy**

thuythnsb60939@fpt.edu.vn

**Nguyen Huu Minh Tam**

tamnhmsb60993@fpt.edu.vn

**Nguyen Quang Hai**

hainqsb60484@fpt.edu.vn

**Students of Software Engineering &  
Information Assurance Faculty,  
HCM FPT University**

**Nguyen The Phuong**

phuongntse62087@fpt.edu.vn

**Phan Thanh Thuan**

thuanptse62063@fpt.edu.vn

**Nguyen Cao Duy**

duyncse61032@fpt.edu.vn

**Nguyen Luong Tuan Kiet**

kietnlts61696@fpt.edu.vn

**Le Hung Son**

sonlhse61849@fpt.edu.vn

**Vo Hoang Viet**

vietvhse61846@fpt.edu.vn

**Nguyen Thanh Nha**

nhantse61236@fpt.edu.vn

**Nguyen Kien Huy**

huynkse61871@fpt.edu.vn

**Nguyen Toan Nguyen**

nguyenntse61816@fpt.edu.vn

**Hoang Manh Cuong**

cuonghmse61977@fpt.edu.vn

**Ha Huy Hoang**

hoanghhse61853@fpt.edu.vn

**Dam Tien Nam**

namdtse61537@fpt.edu.vn

**Vo Truong Thinh**

thinhvtse61766@fpt.edu.vn

**Truong Chieu Khang**

khangtse61785@fpt.edu.vn

**Tran Tat Dat**

datttse61503@fpt.edu.vn

**Duong Trieu Anh**

anhdtse61806@fpt.edu.vn

**Hoang Nguyen Minh Giang**

giangnhmse61931@fpt.edu.vn

**Ngo Quang Duy**

duynqse61772@fpt.edu.vn

**Dang Manh Hung**

hungdmse61294@fpt.edu.vn

**Hoang Phi Long**

longhpse62021@fpt.edu.vn

**Nguyen Dinh Phong**

phongndse61968@fpt.edu.vn

**Trinh Binh**

binhtse61780@fpt.edu.vn

**Nguyen Bui Hoang Minh**

minhnbhse61805@fpt.edu.vn

**Le Thien Duy**

duyltse61908@fpt.edu.vn

**Doan Bao Quyen**

quyendbse61910@fpt.edu.vn

**Nguyen Nhat Ha**

hannse61793@fpt.edu.vn

**Ho Thai Thien**

thienttse61956@fpt.edu.vn

**Vo Cong Phuc**

phucvcse60975@fpt.edu.vn

**Pham Tran Anh Tu**

tuptase62058@fpt.edu.vn

# **Awards & Photos Appendix**



### Evaluation criteria

- The score of the review committee accounted for 60%
- Audience at the auditorium vote account for 40%: Audience at the auditorium vote according to the criteria: Application of the subject in practice; Presentation ability of the group.

**Total score: 100 points**

### Level

**Very good (100 points)**

Good (90 points)

Normal (80 points)

Low (70 points)

### Conference Awards

#### First Prize:

##### Electricity Invoice System

Duong Trieu Anh, Hoang Nguyen Minh Giang, Ngo Quang Duy, Dang Manh Hung

#### Second Prize:

##### Design and Implement Street Lighting Control System Using Power Line Communication

Vo Trung Thinh, Truong Chieu Khang, Tran Tat Dat

#### Third Prize:

##### Call-Center on Mobile for Clinics

Nguyen The Phuong, Phan Thanh Thuan, Nguyen Cao Duy, Nguyen Luong Tuan Kiet

#### Consolation Prize:

##### Analyzing the Factors of Choosing Payment Methods in Online Shopping: A Study of Atadi.vn

Diep Phuong Thanh, Dinh Trung Hieu, Lai Thi Thao My, Pham Huynh Vinh Phuong

##### Evaluating the Disability Customers' Satisfaction of the Public Transportation in Ho Chi Minh City

Phan Duc Minh, Hoang Thi Tu Anh, Trinh Thi Yen Anh

##### Criminal Face Detection

Le Hung Son, Vo Hoang Viet, Nguyen Thanh Nha, Nguyen Kien Huy



##### Vietnamese Keyword Extraction Using Deep Learning Approach

Nguyen Toan Nguyen, Hoang Manh Cuong, Ha Huy Hoang, Dam Tien Nam





**ANALYZE THE CURRENT SITUATION OF SABECO'S MARKETING COMMUNICATION PROGRAMS AND GIVING RECOMMENDATIONS FOR IMPROVING ITS IMC STRATEGY**

**FPT UNIVERSITY**

Huynh Tieu My, Luong Nhat Duy, Nguyen Duc Duy, Tran Xuan Dac  
FPT University, Ho Chi Minh City, Vietnam

### Abstract

SABECO is one of the leading brands in the beverage industry in Vietnam. SABECO focuses strongly on developing beer products and Saigon Special is product that has been concentrated many resources of the company. Other competitors have invested a lot in IMC to develop their brand, so SABECO is trying to concentrate many resources for Saigon Special to win this market share. Moreover, the diversity in the beer market nowadays makes companies focus on branding, especially brand awareness to increase their position in the minds of consumers.

**Keywords:** Integrated Marketing Communication, IMC, brand, brand awareness, Current situations marketing communication, SABECO, Saigon Special.

### Literature Review

In this section, we give definitions of IMC, the definition of brand awareness, how IMC's elements influence brand awareness in the world's most popular research papers. Based on the above theories, we make assumptions about the influence of IMC factors on brand awareness.

### Findings

After research and analyze data, we have clarified the research objectives.

**Finding 1:** Following this research, there are 4 tools which influence to Saigon Special Brand Awareness: Advertising, Personal Selling, Public Relation, Sale Promotion. Direct Marketing do not have significant in this reaches model because the Sig value of the DM variable is greater than 0.05.

**Finding 2:** Saigon Special and Others Beer Brand in Vietnam are using 4 tools of IMC for building brand awareness: Advertising, Personal Selling, Public Relation, Sale Promotion. However, comparing with other brands, Saigon Special has not done it's IMC well, so Saigon Special need to improve it's IMC.

**Finding 3:** Tool "Advertising" is the strongest affect the level of brand awareness with Beta=0.514, next tool is "Personal Selling" with Beta= 0.418. Then tool "Public Relation" with Beta= 0.405. After that is tool "Sale Promotion" with Beta= 0.062. Therefore Saigon Special should allocate marketing resources in descending order: Advertising, Personal Selling, Public Relation, Sale Promotion.

**Finding 4:** Advertising on Internet, Discount, Organizing and sponsoring events and Salesman (PG) in restaurants are the best forms of marketing communication that correspond to four IMC tools: Advertising, Sale Promotion, Public Relation, and Personal Selling to increase the level of beer brand awareness in Vietnam.

### Introduction

According to officially website of Saigon Special, nearly 20 years ago, when the Vietnamese economy started to integrate itself, the domestic beer market was still bored by local beer brands that were almost identical and included in fermented ingredients, from cereals. In the fierce competition, the management of the Saigon beer was anxious to make a breakthrough decision.

The main objectives of this study are to show and analyze the current situation of SABECO's marketing communication programs for increase Saigon Special Brand Awareness and also giving recommendation for improving its IMC strategy to enhance Brand in fierce competition with other foreign and domestic competitors.

The question asked for this study was: *"What are the IMC's tools which are needed to improve Saigon Special Brand Awareness?"*

### Methodology

The first step, we identified the process of the study:

```

graph TD
    A[Identify Research problem] --> B[Interview]
    B --> C[Literature review]
    C --> D[Research method discussion]
    D --> E[Data collection]
    E --> F[Data processing and Analysis]
    F --> G[Findings]
    G --> H[Recommendation]
    H --> I[Report preparation and presentation]
    
```

In the second step, we introduce theories of scale measurement, the theories of survey question formulation. Finally, we provide sample selection and analysis of survey data.

```

graph TD
    A[Descriptive Statistic Analysis] --> B[Reliability Test]
    B --> C[EFA Test]
    C --> D[Correlation Analysis]
    D --> E[Regression]
    E --> F[Hypothesis Testing]
    F --> G[Discrimination Analysis in Demographic Variables]
    
```

### Data analysis

We used SPSS 20 software to analyze the data based on the steps in data analysis.

### Recommendation

The author's recommendations are increasing the frequency and effectiveness of the activities of each of these tools, and smartly selecting the appropriate types to avoid having any negative impact on the brand.

**Subject's Poster: Analyze the Current Situation of Sabeco's Marketing Communication Programs and Giving Recommendations for Improving Its IMC Strategy**



**FPT UNIVERSITY**



## EVALUATING THE DISABILITY CUSTOMERS' SATISFACTION OF THE PUBLIC TRANSPORTATION IN HO CHI MINH CITY

Members:

Phan Duc Minh  
Hoang Thi Tu Anh  
Trinh Thi Yen Anh

Supervisor:

Tran Dinh Thanh



Although Vietnam has paid more attention to space for PWDs and there have been many constructions designed to enable PWDs to have access, the number of accessible works for PWDs be at the fingertips. Because of that delay, PWDs have insufficient access to a small number of national projects, and much other public works. As regards our study, we would like to address the necessity of this research to incorporate comprehensive research, including statistics and arguments, for both the Disability policy advocacy progress and implementation of related organizations to envision an optimistic scenario for the needed ones.

**Subject's Poster: Evaluating the Disability Customers' Satisfaction of the Public Transportation in Ho Chi Minh City**



**Call-Center on Mobile for Clinics**  
 Advisor: Kiều Trọng Khánh  
 Member: Nguyễn Thế Phương, Phan Thành Thuận, Nguyễn Lương Tuấn Kiệt, Nguyễn Cao Duy



**STARS**  
 RATED FOR EXCELLENCE  
 2012



**FPT UNIVERSITY**

**ABSTRACT**

- At the present, the clinic usually uses traditional ways to receive the call, that is hiring a switchboard operator. But, that solution has a few problems such as missed call or receive the wrong information.
- Another way to solve this problem for the clinic is Call-Center, the clinic will rent the traditional Call-Center to receive the call from patients. but the cost is quite expensive and it is hard to exchange appointment information for the clinic.
- That is the reason why we decided to build an automatically Call-Center system to save time and cost for the clinic. The system will pick up the call automatically, receive information and schedule appointment for the patient. After that, the system will send SMS about appointment information for the patient.
- Keywords:** Automatically Call-Center, Schedule appointment, Speech To Text, Text To Speech.

**INTRODUCTION**

- Call-Center on mobile for clinic is the system we build to provide booking appointment services for the patient by hotline phone number.
- Booking appointment service by the call is the way we allow patient call to clinic phone number and interactive with the system to make appointment. To do that we need to control a clinic's phone number, that is mean when clinic's phone number have any incoming call, our system will pick up a call automatically, answer to the patient by a voice and also receive information when patient talk.
- In the detail, we build booking appointment service with flowing flow:
  - When a patient call to clinic's phone number, we pick up a call automatically.
  - Then answer to the patient by hello message and guiding patient how to book appointment.
  - Next step is listen patient's information
  - Once the patient's information is available, the system will analyze that data and make appointment.
  - The last thing is the system will announce appointment's information to patient.

**PROBLEM AND SOLUTION PLAN**

- We decide to use smartphone as a switchboard to receive and answer a call. And event after many hours research we find the way to done the first step is auto pick up phone call (only working on Samsung's device). We instantly face another problem, we cannot send voice answer when we are receiving the call. So, we fall in that way.
- After that, we change the way of looking for this problem, that is building a system with O2 servers, the first one is the Hotline Server which provides any services of our system, and the second is Clinic Server which controls the clinic phone number. Both communicate with each other using Web API.
- Clinic Server listens to some events like incoming SMS signal, incoming call signal, hang up, etc. If any event occurs, Clinic Server will send a request to Hotline Server to handle that event. Our two big issues are sending voice answer to the patient and collecting information when patient talk, these issues will be resolved by Clinic Server as follows:
  - Collecting information when patient talk: Clinic Server record a call and save it into a file, then send a recorded file and related information to Hotline Server.
  - Send voice answer to the patient: Hotline Server translates text to a voice and save this voice into a file, then send the audio file to Clinic Server. The last thing, Clinic Server just play that audio file to patient.

**PLAN IMPLEMENTATION**

- Schedule appointment
  - The appointment time is calculated based on formula:
 
$$\text{Estimate\_Time} = \text{Base\_Time} + \text{Examination\_Duration}$$
  - Detail description:
    - Estimate\_Time: The time estimated for new appointment
    - Base\_Time:
      - If no appointment made on that day, Base\_Time is Start\_Working and set Examination\_Duration = 0
      - If clinic has any appointment on that day, Base\_Time is the time of Last\_Appointment
    - Examination\_Duration: The duration for one examination which configured by clinic
- Book appointment by the call
  - The processing model of booking appointment following these steps:
    - Guiding the patient book appointment when system receive a call.
    - Analyzing patient's information which input on the call
    - Estimation time for appointment using "Schedule Appointment" algorithm
    - The announcement about appointment's information for patient and clinic

**PROCEDURE**

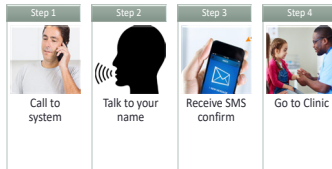

**CONCLUSIONS**

- Our system provides automatically Call-Center for the clinic, this is our exertion to help the clinic reduce costs and save the time. However, limit of the time forces us to uses some third-party frameworks and that makes a performance of the system is not good.
- We are want to send a big thanks to our advisor, Mr. Kieu Trong Khanh. About his idea and the way he guides us, leads us to overcome difficulties in this project.

**REFERENCES**

- Twilio documents "https://www.twilio.com/docs/"
- Book appointment by SMS
  - The processing model of booking appointment following these steps:
    - Check appointment booking
    - Estimation time for appointment using "Schedule Appointment" algorithm
    - Announcement about appointment's information for patient and clinic base on estimation time, our system will announce appointment information to patient and clinic.

**Subject's Poster: Call-Center on Mobile for Clinics**



**STARS**  
 RATED FOR EXCELLENCE



**FPT UNIVERSITY**

**CRIMINAL FACIAL DETECTION SYSTEM**

# CFDS

In recent years, insecurity situation, robbery and theft have risen quickly specially in public places such as hospitals, supermarkets and retail businesses and these have caused undue harm to businesses and consumers. Businesses have to invest a huge amount of money in security cameras and hiring a large number of security staffs, but a few security staffs can not pay enough attention for many cameras to observe and recognize all dangerous persons. Because of these, the businesses are demanding a system that improves the camera's automatic surveillance capabilities, and is able to alert operators to increase the efficiency of their enterprise security systems.

We built the Criminal Facial Detection System (CFDS), a system that identifies criminals' face with detail information and warns security staffs so they can be alert to dangerous person and handle them promptly, avoid possible losses. In addition, businesses can be more proactive in monitoring security by tracking the people they do not want to appear at their stores, supermarkets or hospitals.

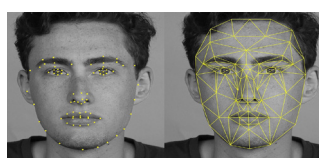

**Supervisor**

Nguyen Huy Hung

**Members**

- Le Hung Son
- Vo Hoang Viet
- Nguyen Thanh Nha
- Nguyen Kien Huy

**Subject's Poster: Criminal Face Detection**

## VIETNAMESE KEYWORD EXTRACTION USING DEEP LEARNING APPROACH

Nguyen Toan Nguyen – Hoang Manh Cuong – Ha Huy Hoang – Dam Tien Nam  
Student at FPT University



### ABSTRACT

Keywords provide a short way of reflecting a main idea of the document, giving the reader easier to clear.  
This paper has proposed a solution for the automatic keyword extraction in Vietnamese language using deep learning approach.

### PROPOSED MODEL

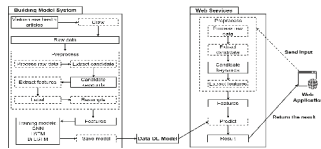

#### Candidate keyword identification

To select candidate noun phrases for a given document, we take the full-text content of the document as described above and apply our PoS Pattern (Part of Speech pattern):  
<N...>+ <A...> <E...> <N...>+ <A...>  
<N...>+: One or more of any type nouns  
<A...>: Any number of adjectives  
<E...>: One or zero of preposition

#### Extracting features

Our team extract features for candidate keywords from five concepts:  
• Word Embedding with Pre-trained model  
• Named-Entity Recognition  
• Frequency-based  
• Position  
• Phrase Length and Word Length

#### Word Embedding

We applied Word Embedding to represent a keyword keyword – can be combined by 2 or more words – as a vector by plus vectors to each word in the dictionary we build.

### INTRODUCTION

Identifying keywords from the documents has helped to solve many practical problems such as: Searching for information, summarizing text, mining text, browsing website...  
In particular, keywords allow people to search faster, easier and more effective. Analyzing keywords, searchers can identify the important information in a large dataset quickly.

#### Named-entity recognition

Number of words in Noun Phrase: nNP  
Number of named-entity words in Noun Phrase: nNER

$$F_{ner} = nNER/nNP$$

#### Frequency-based

Number of times a noun phrase occurs independently in a document: Phrase Frequency (PF).  
Number of times a noun phrase appears in full as a part of other noun phrases: Phrase Link Count (PLC)

$$F_{freq} = \sqrt{(1/2 * PF * PF + PLC)}$$

IDF value is a measure for determining the rarity of a term in a corpus.

$$F_{idf} = F_{freq} * IDF$$

i = the position of a noun phrase occurred first in the document

$$F_{pos} = 1/i$$

#### Phrase Length and Word Length

• Length of a noun phrase: PL  
• Length of characters in the noun phrase: WL

$$F_{plwl} = \sqrt{(\log(1 + PL) * \log(1 + WL))}$$

#### Keyword extraction using deep learning methods

In this paper, we apply 3 Deep Learning model: LSTM, Bi-LSTM, CNN. The output determine which candidate keyword is a keyword (1) or not (0)

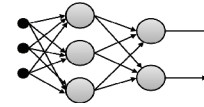

### EXPERIMENT

Model	Precision	Recall	F1-Score
CNN	0.1814	0.0714	0.0857
LSTM	0.2336	0.8888	0.3464
Bi-LSTM	0.2752	0.3331	0.2822
CNN with Pre-trained word2vec	0.2914	0.6618	0.3764
LSTM with Pre-trained word2vec	0.3113	0.6414	0.3879
Bi-LSTM with Pre-trained word2vec	0.3466	0.6014	0.4051

### CONCLUSION

This paper has presented a solution for automatic extract keyword in Vietnamese texts.

### REFERENCE

LeCun et al.(1999), "Object Recognition with Gradient Based Learning"  
Schuster M., Paliwal K.K. Bidirectional recurrent neural networks.  
Hochreiter, Sepp; Schmidhuber, Jürgen (1997-11-01). "Long Short-Term Memory". *Neural Computation*. 9 (8): 1735–1780.

## Subject's Poster: Vietnamese Keyword Extraction Using Deep Learning Approach

## Design and implement STREET LIGHTING CONTROL SYSTEM using power line communication (PLC)

Vo Trung Thinh  
Truong Chieu Khang  
Tran Tai Dat

### ABSTRACT

**Powerline Communication** is a new communication technology that enables sending data over existing power cables. This means that, with just power cables running to an electronic device, one can both power it up and at the same time control/retrieve data from it in a half-duplex manner. In many developed countries, PLC is widely applied in street lighting, industrial, machine-to-machine, and transport. However, some developing countries have a little knowledge in PLC, therefore, it is not able to considered replacing other legacy communication technologies in those countries in spite of its advantages. So, we decided to make a research of PLC technology and apply it in the street lighting control system in order to show how it works and demonstrate its benefits in real situations.

### PLAN IMPLEMENTATION

### REFERENCES

- (1) User manual - General purpose ST7540 power line modem module based on ST7540 PLM and STM32 microcontroller. <https://www.wst.com/en/evaluation-tools/steval-hp05v1.1.html#design-scrll>
- (2) ST7540 - FSK power line transceiver datasheet. <https://www.wst.com/en/evaluation-tools/steval-hp05v1.1.html#design-scrll>
- (3) <https://www.element14.com/community/docs/DOC-81033/gener-al-purpose-power-line-modem-module-based-on-the-st7540-plm-and-stm32-microcontroller>
- (4) <https://uk.s-online.com/web/p/modem-ics/688215/>
- (5) <http://dostmuhammad.com/blog/tcp-connection-over-gprs-using-sim900-and-similar-modems-using-at-commands/>
- (6) [https://www.eeflmes.com/document.asp?doc\\_id=1279014](https://www.eeflmes.com/document.asp?doc_id=1279014)

### INTRODUCTION

There are many communication protocols such as Bluetooth, Zigbee, LoRa, Ethernet or RS485 which are considered to be used for constructing a new street lighting control system. However, all of them cannot solve the problems of installation cost and high demands of security. Otherwise, power-line communication is the best solution for this situation thanks to its advantages. Firstly, it limits access to the system from outside. Secondly, PLC uses existing powerline for communication within a local network, so, it helps to reduce installation and maintenance cost. Overall, our system includes a webserver, which user can control street lighting groups via wireless communication by using a GSM/GPRS network. About hardware, we use a concentrator called gateway and other nodes. The gateway, where receive control signals from the webserver, also communicate with other nodes in the network to control the lamps.

### BASIC CONCEPT

### RESULTS

- All street lights in a power grid are controlled directly by web application.
- By using FSK modulation technique, we reduce noises in transmission line to a minimum.
- One gateway can communicate with maximum 30 nodes so that the total delay time is less than 30 seconds.
- Transmission time between 2 PLM modules is less than 2 seconds.
- The difference of synchronization time between 2 modules is less than 0.5 seconds, so, every node which is set the same schedule time, turns on/off light concurrently.

### PROBLEM

Many communication protocols such as LoRa, Bluetooth, Zigbee, Ethernet or RS485 which are considered to be used for developing a new street lighting system. Some of them can solve those problems above, but, all of these protocols are not the best ways in this situation. For example, if using wireless communication, it is easy for crooks to attack the system from outside and the transmission speeds are quite slow. Otherwise, if using some wire communication protocols like Ethernet or RS485, there are many disadvantages of installation cost and security too.

### SOLUTION

There are a lot of benefits of using PLC that can solve all above problems of other communication protocols.

- Devices using PLC can interact with each other directly.
- Using many techniques to ensure data integrity in transmission such as FHSS, CSMA/CA, etc.
- Easy to install and extend.
- High speed data transmission.
- Use existing power grid for communication, so, reduce installation and maintenance costs.
- Closed network can limit access and attack from outside intruders.

### CONCLUSION

Our research of the PLC technology shows that it is a great potential which can be applied in several areas. However, there are a lot of risks involved when starting to develop a new technology. But, we believe that PLC can replace many legacy protocols because the most reasonable benefit of PLC is that it use existing power grid to transmit data. Therefore, it helps to reduce cost of materials, installation and maintenance.

### ACKNOWLEDGMENT

We would like to give a special thanks to my supervisor, **Mr. Nguyen Duc Loi** for his professional guidance and advices during the process of researching and implementing the project. We especially appreciate his assistance of supporting devices for our research.

## Subject's Poster: Design and Implement Street Lighting Control System Using Power Line Communication



# ELECTRICITY INVOICE SYSTEM

BY DUONG TRIEU ANH, HOANG NGUYEN MINH GIANG

## INTRODUCTION

Nowadays, invoice management work in businesses is becoming more and more difficult because there are too many bills and complex documents that need to be processed. When customers want to see invoice information, they often have to wait for company's employees to send invoices to their house. This process can be very tiring and time-consuming. Besides, companies always want to optimize time efficiency and productivity in order to bring their service to customers as quickly as possible. Therefore, we are building a web application, which helps users to solve current problems.

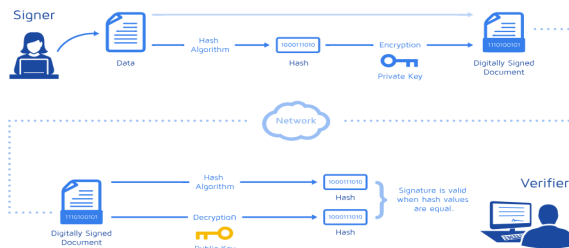

## PROBLEMS & SOLUTION

- Time-consuming
- High chances of errors, fake invoices
- Difficulty in monitoring, management
- Waste of cost

The proposed solution is to build a web application that allows companies to create and manage their own invoices, along with proforma invoices, easily.

## PLAN IMPLEMENTATION

- Guests can login if account is registered.
- System administrators can manage all companies and all accounts.
- Managers can manage their company's staffs, products, templates, customer list.
- Accounting managers can view and approve proforma invoices, view and sign invoices with company's digital signature.

## EXPERIMENT RESULTS AND CONCLUSION

We have executed some testing on our application. These are the results: successfully manage and publish invoices with digital signature; other management tasks also work smoothly.

After many experiments, we conclude that HIIS is suitable and worth for invoice management.



### Subject's Poster: Electricity Invoice System



## DESIGN AND CONSTRUCTION SUN DRYING WET CLOTHES SYSTEM

by  
**Hoàng Phi Long**  
**Nguyễn Đình Phong**  
**Trịnh Bình**

### ABSTRACT

Vietnamese have long working hours which means they spend time at evening and night to do their chores. The chores include washing and drying clothes. However, Vietnam also has long rainy season which indicate a persistent problem of inefficient clothes drying process.

### INTRODUCTION

An automatic clothes drying system, which uses rain sensor to detect rain and ESP8266 for communications between mobile application and device, was developed to allow consumers to effectively manage their chores. We hope the system will help resolve some aspects of the problem that the current face recognition systems are facing today.

### IMPLEMENTATION

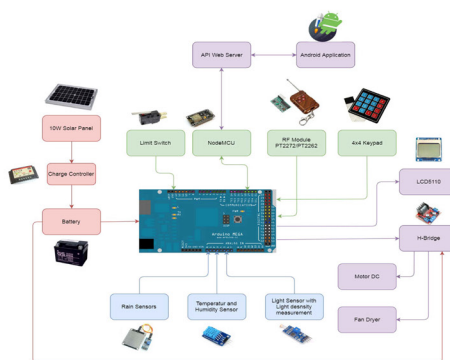

The block diagrams above shows that system has the following features:

- Rain and Night auto detection from sensors data
- Control system via RF Remote
- Control system via Keypad
- Control system via Mobile application
- Having dryer system
- Using solar energy

### EVALUATION

#### Achievement:

- Can be controlled via mobile
- Rain detection within 50ms.
- Works with 95% accuracy.

#### Limitations:

- Cannot determine whenever clothes is dry or not.
- Cannot determine wherever rain is stopped or not

#### Further Suggestions:

- Improve detection feature with Hidden Markov Model
- Implement more control methods

### CONCLUSION

Our research shows that the DCCS system has a great potential to succeed. However, there are limitations to the system such as its inability to detect rain using Mathematics process. These limitations need to be improved to give the product a competitive advantage over other competitors

### Subject's Poster: Design and Construction Sun Drying Wet Clothes System





**Mr. Than Van Su was speaking to start the Conference**



**Team 1 was presenting paper with title: “Analyzing the Factors of Choosing Payment Methods in Online Shopping: A Study of Atadi.vn”**

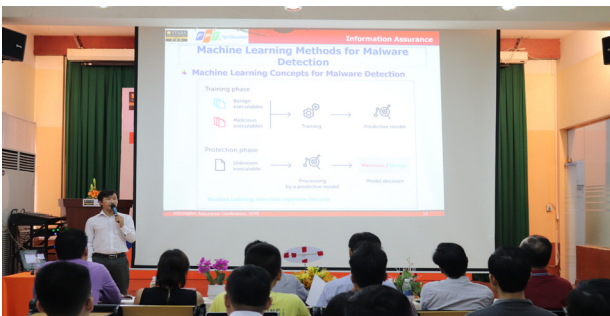

**Keynote Speech 1: “Reduce Risk to Ransomware Attack and Improve Operational Security” presented by Mr. Nguyen Sieu Dang**



**Team 2 was presenting paper with title: “Evaluating the Disability Customers’ Satisfaction of the Public Transportation in Ho Chi Minh City”**



**Keynote Speech 2: “Perceived Tourism Service Quality of Chinese Outbound Tourists: A Case Study of Nha Trang Tourism Industry” presented by Doan Kim Loan**



**Team 3 was presenting paper with title: “Call-Center on Mobile for Clinics”**



**The Scientific Council was inspecting reports of teams**



**Team 4 was presenting paper with title: “Criminal Face Detection”**





**Team 5 was presenting paper with title:  
“Vietnamese Keyword Extraction  
Using Deep Learning Approach”**



**Questions from the Scientific Council**



**Team 6 was presenting paper with title:  
“Design and Implement Street Lighting Control  
System Using Power Line Communication”**



**Questions from the Students**



**Team 7 was presenting paper with title:  
“Electricity Invoice System”**



**The Students was listerning  
presentation of teams**



**Questions from the Scientific Council**



**The closing speech of Mr. Than Van Su**





**The speech of Mr. Dinh Truong Lam - Organization Board Representative**



**The Scientific Council take a photograph with winning teams**



**Mr. Than Van Su & Mr. Nguyen Huu Hoang Giao awarded certificates to the winning teams**



**Taking commemorative photograph with winning teams**



**Mr. Than Van Su awarded certificates to the winning teams**



**A scene of conference**



**The Students won first prize**



**Posters were displayed at FPTU Student Research Conference - Summer Semester 2018**



Readers can find The Student Research Conference Proceedings Vol. 1 - 4 in Library Department of HCMC FPT University and Ha Noi FPT University, also find it by electronic version on Dspace at link: <http://ds.libol.fpt.edu.vn>



#### **HA NOI**

Education and Training Zone -  
Hoa Lac Hi-Tech Park - Km29,  
Thang Long Highway, Thach  
That, Hanoi  
Tel. (+84-24) 73005588  
Email: [daihocfpt@fpt.edu.vn](mailto:daihocfpt@fpt.edu.vn)

#### **HO CHI MINH CITY**

2nd Floor, Innovation Building,  
Block 24, Quang Trung Software  
Park - Tan Chanh Hiep Ward,  
District 12, HCMC  
Tel. (+84-28) 73005588  
Email: [daihoc.hcm@fpt.edu.vn](mailto:daihoc.hcm@fpt.edu.vn)

#### **DA NANG**

137 Nguyen Thi Thap  
Lien Chieu District, Da Nang  
Tel. (+84-236) 7300999  
Email: [daihocfpt@fpt.edu.vn](mailto:daihocfpt@fpt.edu.vn)

#### **CAN THO**

160, 30/4 Street, An Phu Ward,  
Ninh Kieu District, Can Tho City  
Tel. (+84-292) 7303636  
Hotline: (+84) 909070357  
Email: [fptu.cantho@fe.edu.vn](mailto:fptu.cantho@fe.edu.vn)